PAW3101DB CMOS OPTICAL MOUSE SENSOR

General Description

The PAW3101DB is a CMOS process optical mouse sensor with DSP integration chip that serves as a non-mechanical motion estimation engine for implementing a computer mouse.

Features

- Single 5.0/3.3 volt power supply
- Precise optical motion estimation technology
- Complete 2-D motion sensor
- No mechanical parts
- Accurate motion estimation over a wide range of surfaces
- High speed motion detection up to 21 inches/sec
- High resolution up to 800 CPI
- Register setting for low power dissipation
- Power saving mode during times of no movement
- Serial Interface for programming and data transfer
- I/O pin 5.0 volt tolerance

Key Specification

Power Supply	Wide operating supply range 3.0V ~ 3.6V (VDD, VREF) 4.25V ~ 5.5V (VDD)
Optical Lens	1:1
System Clock	18.432 MHz
Speed	21 inches/sec
Resolution	400/800 CPI
Frame Rate	3000 frames/sec
Operating Current	10mA @Mouse moving (Normal) 5mA @Mouse not moving (Sleep) 100uA @Power down mode
Package	Staggered DIP8

Ordering Information

Order Number	I/O	Resolution
PAW3101DB	CMOS output	800 CPI

1. Pin Configuration

1. Pin Description

Pin No.	Name	Type	Definition
1	OSCIN	IN	Resonator input
2	OSCOOUT	OUT	Resonator output
3	SDIO	I/O	Serial interface bi-direction data (5.0 volt tolerance and 3.3V output)
4	SCLK	IN	Serial interface clock (5.0 volt tolerance)
5	LED	OUT	LED control
6	VSS	GND	Chip ground
7	VDD	PWR	Chip power, 3.0V ~ 3.6V(V_{dd1}) or 4.25V ~ 5.5(V_{dd2})
8	VREF	BYPASS	Voltage reference, 3.3V

1.2 Pin Assignment

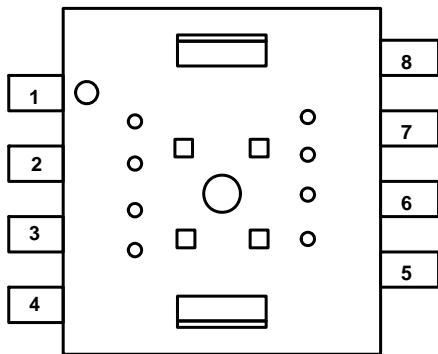

Figure 1. Top View Pinout

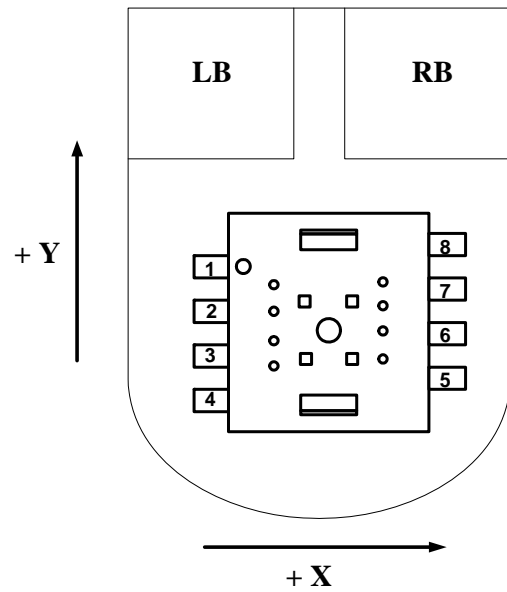

Figure 2. Top View of Mouse

2. Block Diagram and Operation

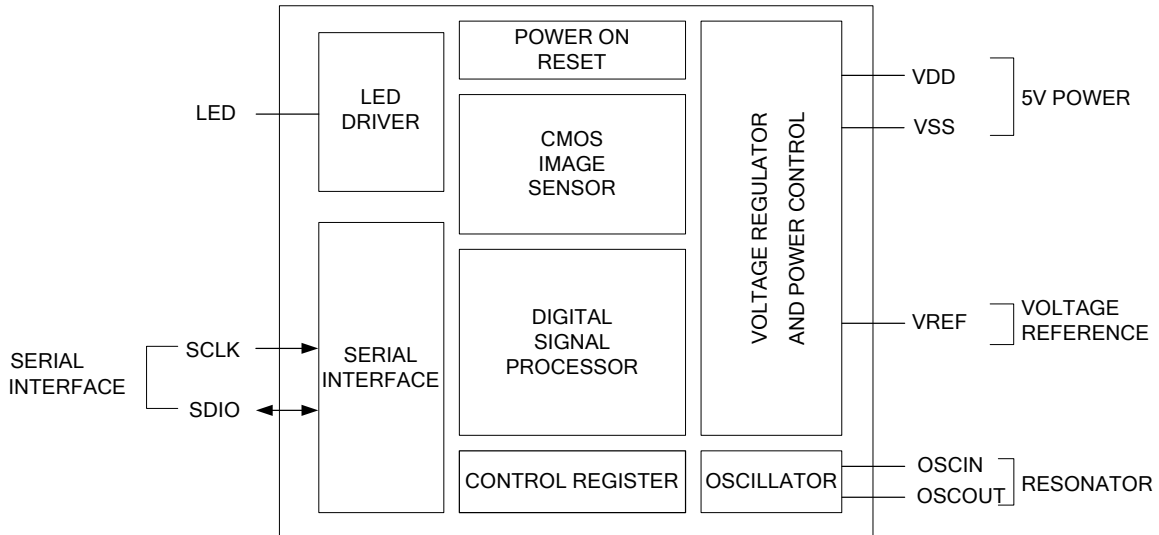

Figure 3. Block Diagram

The PAW3101DB is a CMOS-process optical mouse sensor with DSP integration chip that serves as a non-mechanical motion estimation engine for implementing a computer mouse. It is based on new optical navigation technology, which measures changes in position by optically acquiring sequential surface images (frames) and mathematically determining the direction and magnitude of movement. The mouse sensor is in a 8-pin optical package. The current X and Y information are available in registers accessed via a serial port. The word "mouse sensor," instead of PAW3101DB, is used in the document.

3. Registers and Operation

The released registers of the mouse sensor can be programmed via a serial port interface. The user can modify released DSP configuration and read motion data from these registers. Some registers not being listed are reserved not allowed to be modified.

3.1 Registers

Address	Name	R/W	Reset Value	Data Type
0x00	Operation_Mode1	R/W	0x00	Bit field
0x01	Product_ID1	R	0x01	Bit field
0x02	Delta_Y	R	-	Eight bits 2's complement number
0x03	Delta_X	R	-	Eight bits 2's complement number
0x04	Image_Quality	R	-	Eight bits unsigned integer
0x05 0x13	-	-	-	Reserved for future use
0x14	Product_ID2	R	0x10	Eight bits 11:4] number with the product identifier
0x15	Product_ID3	R	0x1X	Four bits[3:0] number with the product identifier Reserved[3:0] number is reserved for future use
0x16	Motion_Status	R	-	Bit field
0x17	Delta_X	R	-	Eight bits 2's complement number
0x18	Delta_Y	R	-	Eight bits 2's complement number
0x19	Image_Quality	R	-	Eight bits unsigned integer
0x1A	Operation_Mode2	R/W	-	Bit field
0x1B	Configuration	R/W	-	Bit field
0x1C 0x3F	-	-	-	Reserved for future use
0x40	Operation_Mode3	R/W	0x20	Bit field
0x41	Product_ID4	R	0x41	Bit field
0x42	Delta_Y	R	-	Eight bits 2's complement number
0x43	Delta_X	R	-	Eight bits 2's complement number
0x44	Image_Quality	R	-	Eight bits unsigned integer

3.2 Register Descriptions

0x00		Operation_Model						
Bit	7	6	5	4	3	2	1	0
Field	Reset	PD_enh	0	0	0	0	0	Slp_enl
Usage	Register 0x00 allows the user to change the operation of the mouse sensor. Shown below are the bits, their default values, and optional values. If Slp_enl = 0, after 1 sec not moving during normal mode, the mouse sensor will enter sleep mode, and keep on sleep mode until moving is detected or wakeup is asserted.							
Notes	Field Name	Description						
	Reset	Full chip reset 0 = Normal operation mode (Default) 1 = Full chip reset						
	PD_enh	Power down mode 0 = Normal operation mode (Default) 1 = Power down mode						
	Bit [5:1]	MUST always be 00000						
	Slp_enl	Sleep mode enable/disable 0 = Enable (Default) 1 = Disable						
0x01		Product_ID1						
Bit	7	6	5	4	3	2	1	0
Field	PID1[2:0]			Reserved[3:0]				Opstate
Usage	Product ID of the mouse sensor and operation state of the mouse sensor.							
Notes	Field Name	Description						
	PID1[2:0]	The product ID is 000						
	Reserved[3:0]	Reserved for future use						
	Opstate	Operation state 0 = Sleep state 1 = Normal state						
0x02		Delta_Y						
Bit	7	6	5	4	3	2	1	0
Field	Y7	Y6	Y5	Y4	Y3	Y2	Y1	Y0
Usage	Y movement is counts since last report. Absolute value is determined by resolution. Reading clears the register. Report range -128 ~ +127.							

0x03	Delta_X							
Bit	7	6	5	4	3	2	1	0
Field	X7	X6	X5	X4	X3	X2	X1	X0
Usage	X movement is counts since last report. Absolute value is determined by resolution. Reading clears the register. Report range -128 ~ +127.							
0x04	Image_Quality							
Bit	7	6	5	4	3	2	1	0
Field	Imgqa[7:0]							
Usage	Image Quality is a quality level of the mouse sensor in the current frame. Report range 0 ~ 255.							
Notes	Field Name	Description						
	Imgqa[7:0]	Image quality report range: 0(worst) ~ 255(best).						
0x14	Product_ID2							
Bit	7	6	5	4	3	2	1	0
Field	PID2[11:4]							
Usage	The value in this register is fixed. It can be used to verify if the status of the serial communications link is OK.							
0x15	Product_ID3							
Bit	7	6	5	4	3	2	1	0
Field	PID2[3:0]				Reserved[3:0]			
Usage	The value in this register is fixed. PID2[3:0] can be used to verify if the status of the serial communications link is OK. Reserved[3:0] is a value between 0x0 and 0xF, but it can't be used to verify the status of the serial communications.							

0x16		Motion_Status						
Bit	7	6	5	4	3	2	1	0
Field	Motion	Reserved[3:2]		DYOVF	DXOVF	Reserved[1:0]		RES
Usage	<p>Register 0x16 allows the user to determine if motion has occurred since the last time it was read. If so, then the user should read registers 0x17 and 0x18 to get the accumulated motion. It also tells if the motion buffers have overflowed since the last reading. The current resolution is also shown.</p> <p>Reading this register freezes the <i>Delta_X</i> and <i>Delta_Y</i> register values. Read this register before reading the <i>Delta_X</i> and <i>Delta_Y</i> registers. If <i>Delta_X</i> and <i>Delta_Y</i> are not read before the motion register is read a second time, the data in <i>Delta_X</i> and <i>Delta_Y</i> will be lost.</p>							
Notes	Field Name	Description						
	Motion	Motion since last report or PD 0 = No motion (Default) 1 = Motion occurred, data ready for reading in <i>Delta_X</i> and <i>Delta_Y</i> registers						
	Reserved[3:2]	Reserved for future use						
	DYOVF	Motion Delta Y overflow, ΔY buffer has overflowed since last report 0 = No overflow (Default) 1 = Overflow has occurred						
	DXOVF	Motion Delta X overflow, ΔX buffer has overflowed since last report 0 = No overflow (Default) 1 = Overflow has occurred						
	Reserved[1:0]	Reserved for future use						
	RES	Resolution in counts per inch 0 = 800 (Default) 1 = 400						
0x17		Delta_X						
Bit	7	6	5	4	3	2	1	0
Field	X7	X6	X5	X4	X3	X2	X1	X0
Usage	X movement is counts since last report. Absolute value is determined by resolution. Reading clears the register. Report range -128 ~ +127.							
0x18		Delta_Y						
Bit	7	6	5	4	3	2	1	0
Field	Y7	Y6	Y5	Y4	Y3	Y2	Y1	Y0
Usage	Y movement is counts since last report. Absolute value is determined by resolution. Reading clears the register. Report range -128 ~ +127.							

0x19	Image_Quality							
Bit	7	6	5	4	3	2	1	0
Field	Imgqa[7:0]							
Usage	Image Quality is a quality level of the mouse sensor in the current frame. Report range 0 ~ 255.							
Notes	Field Name	Description						
	Imgqa[7:0]	Image quality report range: 0(worst) ~ 255(best).						
0x1A	Operation_Mode2							
Bit	7	6	5	4	3	2	1	0
Field	Reset	PD_enh	0	0	LEDsht_enh	Slp_enh	Slpmu_enh	Wakeup
Usage	<p>Register 0x1A allows the user to change the operation of the mouse sensor. Shown below are the bits, their default values, and optional values.</p> <p>Operation_Mode2[2:0] “0xx” = Disable sleep mode “110” = Force enter sleep “101” = Force wakeup from sleep mode</p> <p>Notes: 1. After 1 sec not moving during normal mode, the mouse sensor will enter sleep mode, and keep on sleep mode until moving is detected or wakeup is asserted. 2. Only one of these two bits <i>Slpmu_enh</i> and <i>Wakeup</i> can be set to 1 at the one time, and the other one has to be set to 0. Note that these bits are self-clear.</p>							
Notes	Field Name	Description						
	Reset	Full chip reset 0 = Normal operation mode (Default) 1 = Full chip reset						
	PD_enh	Power down mode 0 = Normal operation mode (Default) 1 = Power down mode						
	Bit [5:4]	Must always be 00						
	LEDsht_enh	LED shutter enable/disable 0 = Disable 1 = Enable (Default)						
	Slp_enh	Sleep mode enable/disable 0 = Disable 1 = Enable (Default)						
	Slpmu_enh	Manual enter sleep mode, set “1” will enter sleep and this bit will be reset to “0”						
	Wakeup	Manual wake up from sleep mode, set “1” will enter wakeup and this bit will be reset to “0”						

0x1B	Configuration							
Bit	7	6	5	4	3	2	1	0
Field	RES	0	1	0	0	1	0	0
Usage	The <i>Configuration</i> register allows the user to change the configuration of the mouse sensor. Shown below are the bits, their default values, and optional values.							
Notes	Field Name	Description						
	RES	Output resolution setting 0 = 800 (Default) 1 = 400						
	Bit [6:0]	Must always be 0100100						
0x40	Operation_Mode3							
Bit	7	6	5	4	3	2	1	0
Field	Reset	PD_enh	LEDsht_enh	0	0	0	0	Slp_enl
Usage	Register 0x40 allows the user to change the operation of the mouse sensor. Shown below are the bits, their default values, and optional values. If Slp_enl = 0, after 1 sec not moving during normal mode, the mouse sensor will enter sleep mode, and keep on sleep mode until moving is detected or wakeup is asserted.							
Notes	Field Name	Description						
	Reset	Full chip reset 0 = Normal operation mode (Default) 1 = Full chip reset						
	PD_enh	Power down mode 0 = Normal operation mode (Default) 1 = Power down mode						
	LEDsht_enh	LED shutter enable/disable 0 = Disable 1 = Enable (Default)						
	Bit [4:1]	Must always be 0000						
	Slp_enl	Sleep mode enable/disable 0 = Enable (Default) 1 = Disable						

0x41		Product_ID4						
Bit	7	6	5	4	3	2	1	0
Field	PID3[3:0]			Reserved[3:0]				Opstate
Usage	Product ID of the mouse sensor and operation state of the mouse.							
Notes	Field Name	Description						
	PID3[3:0]	The product ID is 010						
	Reserved[3:0]	Reserved for future use						
	Opstate	Operation state 0 = Sleep state 1 = Normal state						
0x42		Delta_Y						
Bit	7	6	5	4	3	2	1	0
Field	Y7	Y6	Y5	Y4	Y3	Y2	Y1	Y0
Usage	Y movement is counts since last report. Absolute value is determined by resolution. Reading clears the register. Report range -128 ~ +127.							
0x43		Delta_X						
Bit	7	6	5	4	3	2	1	0
Field	X7	X6	X5	X4	X3	X2	X1	X0
Usage	X movement is counts since last report. Absolute value is determined by resolution. Reading clears the register. Report range -128 ~ +127.							
0x44		Image_Quality						
Bit	7	6	5	4	3	2	1	0
Field	Imgqa[7:0]							
Usage	Image Quality is a quality level of the mouse sensor in the current frame. Report range 0 ~ 255.							
Notes	Field Name	Description						
	Imgqa[7:0]	Image quality report range: 0(worst) ~ 255(best).						

4. Specifications

4.1 Absolute Maximum Ratings

Symbol	Parameter	Min	Max	Unit	Notes
T _{STG}	Storage Temperature	-40	85	°C	
T _A	Operating Temperature	-15	55	°C	
	Lead Solder Temp		260	°C	For 10 seconds, 1.6mm below seating plane.
V _{DC}	DC Supply Voltage	-0.5	5.5	V	
ESD			2	kV	All pins, human body model MIL 883 Method 3015
V _{IN}	DC Input Voltage	-0.5	5.5	V	SDIO, SCLK, VDD

4.2 Recommend Operating Condition

Symbol	Parameter	Min.	Typ.	Max.	Unit	Notes
T _A	Operating Temperature	0		40	°C	
V _{dd1}	Power Supply Voltage	3.0	3.3	3.6	V	VDD, VREF short
V _{dd2}		4.25	5.0	5.5		VDD
V _N	Supply Noise			100	mV	Peak to peak within 0 - 100 MHz
Z	Distance From Lens Reference Plane to Surface	2.3	2.4	2.5	mm	Refer to Figure 4.
R	Resolution			800	CPI	
A	Acceleration	0.1		20	g	
SCLK	Serial Port Clock Frequency			10	MHz	
F _{CLK}	Clock Frequency		18.432	24.576	MHz	Set by ceramic resonator
FR	Frame Rate		3000	4000	frames/s	3000 frames/s @ F _{CLK} = 18.432 MHz 4000 frames/s @ F _{CLK} = 24.567 MHz
S	Speed	0		21 28	inches/s	21 inches/s @ F _{CLK} = 18.432 MHz 28 inches/s @ F _{CLK} = 24.567 MHz

4.3 AC Operating Condition

Electrical Characteristics over recommended operating conditions. Typical values at 25 °C, $V_{DD} = 5.0\text{ V}$, $F_{CLK} = 18.432\text{ MHz}$

Symbol	Parameter	Min.	Typ.	Max.	Unit	Notes
t_{HOLD}	SDIO Read Hold Time		3		us	Minimum hold time for valid data (refer to Figure 8)
t_{RESYNC}	Serial Interface RESYNC.	1			us	@3000 frame/sec (refer to Figure 9)
t_{SIWTT}	Serial Interface Watchdog Timer Timeout	1.7			ms	@3000 frame/sec (refer to Figure 9)
t_{PDR}	PD Pulse Register			333	us	One frame time maximum after setting <i>PD_enh</i> bit in the <i>Operation_Mode</i> register @3000 frame/sec (refer to Figure 10).
t_{PUPD}	Power Up from Deactivate the Power Down Mode	3		30.5	ms	After t_{PUPD} , all registers contain valid data from first image after deactivate power down mode. @3000 frame/sec
t_{PU}	Power Up from $V_{DD}\uparrow$	3		30.5	ms	@3000 frame/sec
t_r, t_f	Rise and Fall Times: SDIO		25, 20		ns	$C_L = 30\text{ pF}$
t_r, t_f	Rise and Fall Times: ILED		10, 10		ns	LED bin grade: R; $R1 = 100\text{ ohm}$

4.4 DC Electrical Characteristics

Electrical Characteristics over recommended operating conditions. Typical values at 25 °C, $V_{DD} = 5.0\text{ V}$, $F_{CLK} = 18.432\text{ MHz}$

Symbol	Parameter	Min.	Typ.	Max.	Unit	
Type: PWR						
I_{DD}	Supply Current Mouse Moving (Normal)		10		mA	SCLK, SDIO = no load
I_{DD}	Supply Current Mouse Not Moving (Sleep1)		5		mA	
I_{DDPD}	Supply Current (Power Down)		100		uA	SCLK, SDIO = high
Type: SCLK, SDIO						
V_{IH}	Input Voltage HIGH	2.0				
V_{IL}	Input Voltage LOW			0.7	V	
V_{OH}	Output Voltage HIGH	2.4			V	@ $I_{OH} = 2\text{mA}$ (SDIO only)
V_{OL}	Output Voltage LOW			0.6	V	@ $I_{OL} = 2\text{mA}$ (SDIO only)
Type: OSCIN						
V_{IH}	Input Voltage HIGH	2.0			V	When driving from an external source
V_{IL}	Input Voltage LOW			0.7	V	When driving from an external source
Type: LED						
V_{OL}	Output Voltage LOW			150	mV	@ $I_{OL} = 25\text{mA}$

5. Z and 2D Assembly

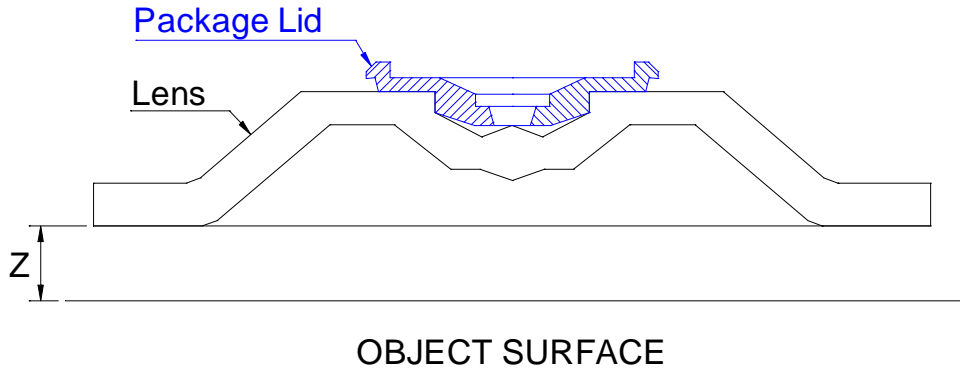

Figure 4. Distance from Lens Reference Plane to Surface

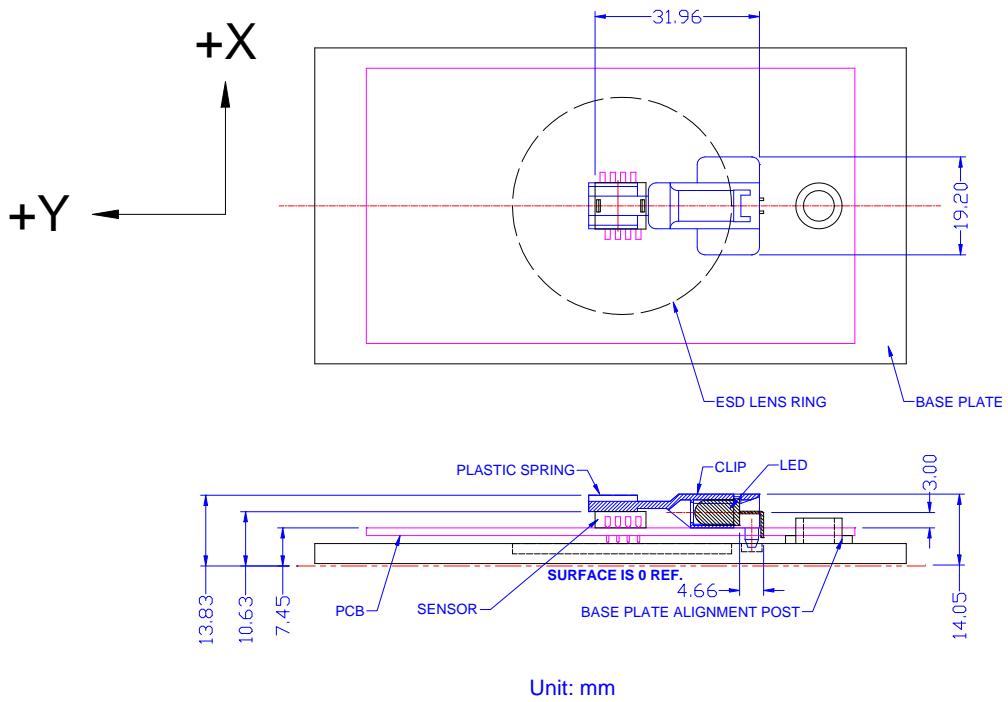

Figure 5. 2D Assembly

6. Serial Interface

The synchronous serial port is used to set and read parameters in the mouse sensor.

SCLK: The serial clock line. It is always generated by the mouse controller.

SDIO: The serial data line is used to write and read data.

6.1 Transmission Protocol

The transmission protocol is a two-wire link, half duplex protocol between the mouse controller and the mouse sensor. All data changes on SDIO are initiated by the falling edge on SCLK. The mouse controller instead of the mouse sensor has the ability to initiates communication.

The transmission protocol consists of the two operation modes:

- Write Operation.
- Read Operation.

Both of the two operation modes consist of two bytes. The first byte contains the address (seven bits) and has a bit7 as its MSB to indicate data direction. The second byte contains the data.

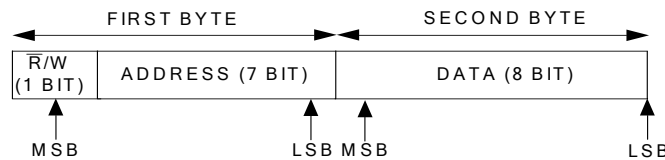

Figure 6. Transmission Protocol

6.1.1 Write Operation

A write operation, which means that data is going from the mouse controller to the mouse sensor, is always initiated by the mouse controller and consists of two bytes. The first byte contains the address (seven bits) and has a “1” as its MSB to indicate data direction. The second byte contains the data. The transfer is synchronized by SCLK. The mouse controller changes SDIO on falling edges of SCLK. The mouse sensor reads SDIO on rising edges of SCLK.

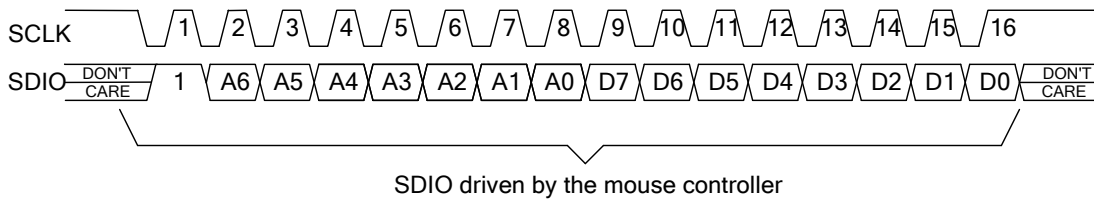
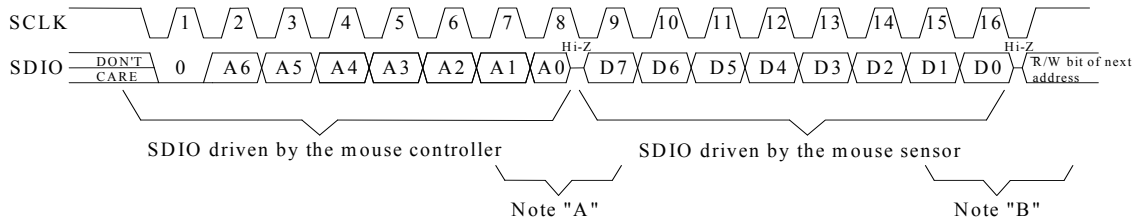

Figure 7. Write Operation

6.1.2 Read Operation

A read operation, which means that data is going from the mouse sensor to the mouse controller, is always initiated by the mouse controller and consists of two bytes. The first byte contains the address, is written by the mouse controller, and has a “0” as its MSB to indicate data direction. The second byte contains the data and is driven by the mouse sensor. The transfer is synchronized by SCLK. SDIO is changed on falling edges of SCLK and read on every rising edge of SCLK. The mouse controller must go to a high Z state after the last address data bit. The mouse sensor will go to the high Z state after the last data bit.



- Note "A" 1. The mouse controller sends address to the mouse sensor.
 2. The mouse controller releases and set SDIO to Hi-Z after the last address bit.

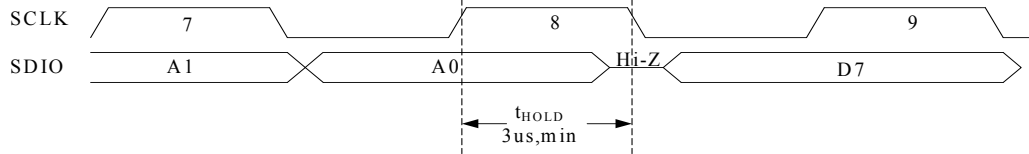

- Note "B" 1. The mouse sensor sends data to the mouse controller .
 2. The mouse sensor releases and set SDIO to Hi-Z after the last data bit.

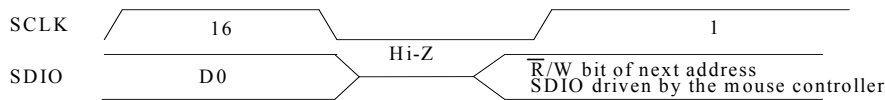

Figure 8. Read Operation

6.2 Re-Synchronous Serial Interface

If the mouse controller and the mouse sensor get out of synchronization, then the data either written or read from the registers will be incorrect. In such a case, an easy way to solve this condition is to toggle the SCLK line from high to low and wait at least t_{SIWTT} to re-synchronous the parts after an incorrect read. This method is called by “watchdog timer timeout”. The mouse sensor will reset the serial port but will not reset the registers and be prepared for the beginning of a new transmission.

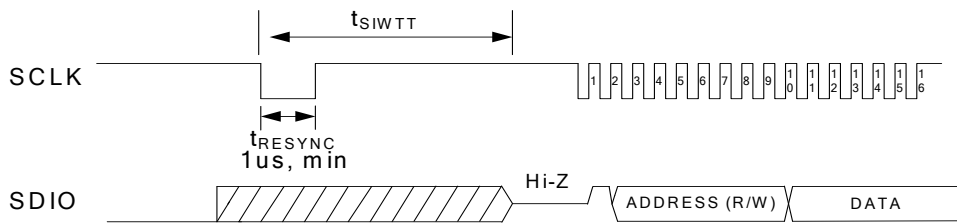

Figure 9. Re-synchronous Serial Interface Using Watchdog Timer Timeout

Note that this function is disabled when the mouse sensor is in the power down mode. If the user uses this function during the power down mode, it will get out of synchronization. The mouse sensor and the mouse controller also might get out of synchronization due to following conditions.

- Power On Problem - The problem occurs if the mouse sensor powers up before the mouse controller sets the SCLK and SDIO lines to be output. The mouse sensor and the mouse controller might get out of synchronization due to power on problem. An easy way to solve this is to use “watchdog timer timeout”.
- ESD Events - The mouse sensor and the mouse controller might get out of synchronization due to ESD events. An easy way to solve this is to use “watchdog timer timeout”.

6.3 Collision Detection on SDIO

The only time that the mouse sensor drives the SDIO line is during a READ operation. To avoid data collisions, the mouse controller should release SDIO before the falling edge of SCLK after the last address bit. The mouse sensor begins to drive SDIO after the next falling edge of SCLK. The mouse sensor release SDIO of the rising SCLK edge after the last data bit. The mouse controller can begin driving SDIO any time after that. In order to maintain low power consumption in normal operation, the mouse controller should not leave SDIO floating until the next transmission (although that will not cause any communication difficulties).

6.4 Power Down Mode

The mouse sensor can be placed in a power-down mode by setting *PD_enh* bit in the *Operation_Mode* register via a serial port write operation. After setting the *Operation_Mode* register, wait at least 1 frame times. To get the chip out of the power down mode, clear *PD_enh* bit in the *Operation_Mode* register via a serial port write operation. In the power down mode, the serial interface watchdog timer (see Section 5.2) is not available. But, the serial interface still can read/write normally. For an accurate report after leave the power down mode, wait about 3ms before the mouse controller is able to issue any write/read operation to the mouse sensor.

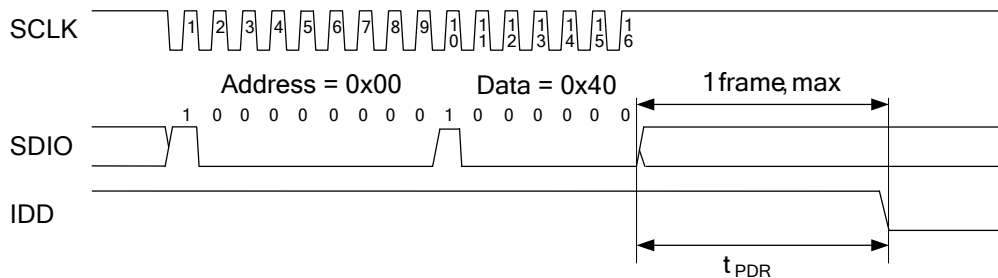

Figure 10. Power-down Configuration Register Writing Operation

6.5 Error Detection

1. The mouse controller can verify success of write operations by issuing a read command to the same address and comparing written data to read data.
2. The mouse controller can verify the synchronization of the serial port by periodically reading the product ID register.

7. Referencing Application Circuit

7.1 5V Application Circuit with External LED Control

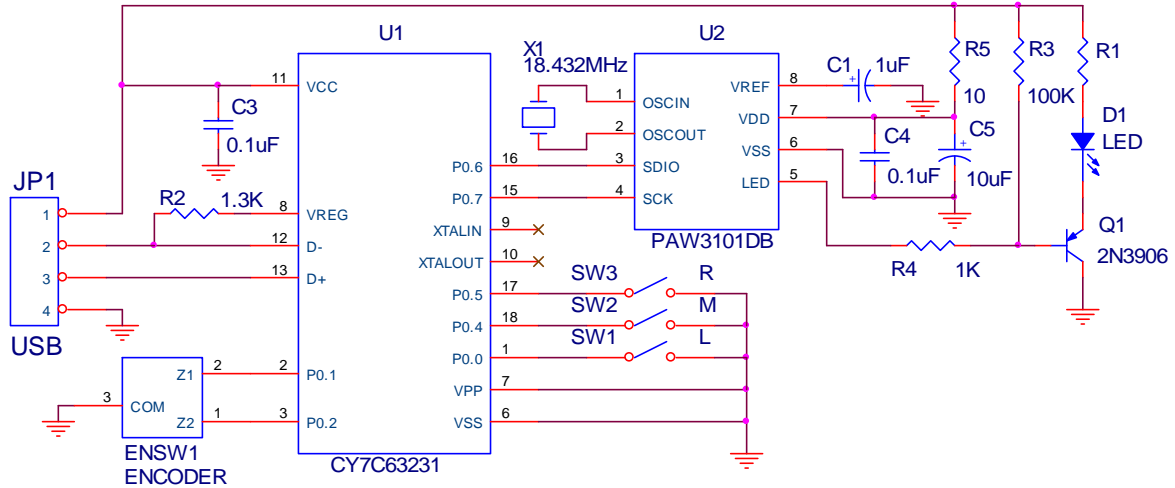

Figure 11. 5V Application Circuit with External LED Control

7.2 5V Application Circuit with Internal LED Control

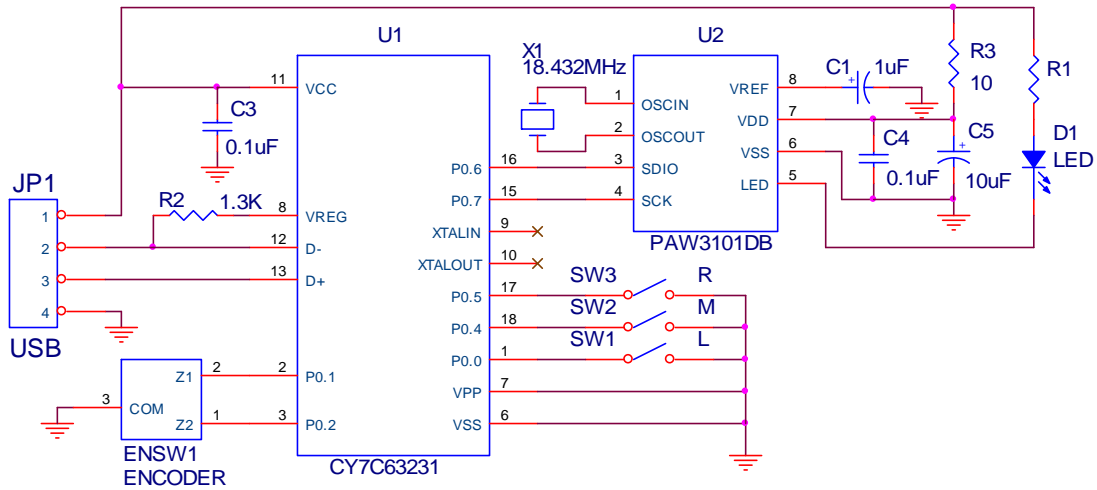

Figure 12. 5V Application Circuit with Internal LED Control

7.3 3.3V Application Circuit with Internal LED Control

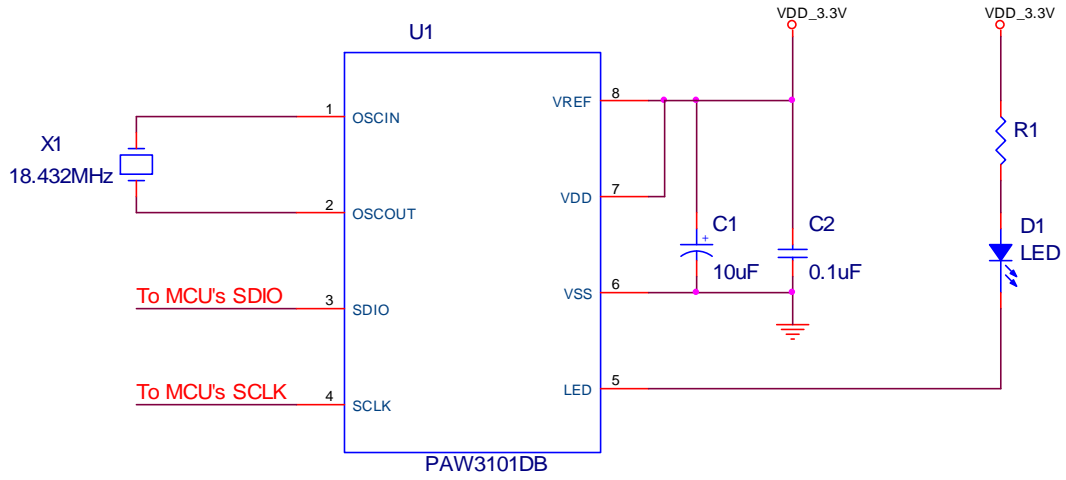

Figure 13. 3.3V Application Circuit with Internal LED Control

7.4 PCB Layout Consideration

- Caps for pins 7, 8 must have trace lengths less than **5 mm**.
- The trace lengths of OSCOUT, OSCIN must less than **6 mm**.

7.5 Recommended Value for R1

- Radiometric intensity of LED
Bin limits (mW/Sr at 20 mA)

LED Bin Grade	Min.	Typ.	Max.
N	14.7		17.7
P	17.7		21.2
Q	21.2		25.4

Note: Tolerance for each bin will be $\pm 15\%$

7.5.1 5V Application

- R1 value (ohm) for external LED control, VDD = 5.0V (refer to Figure 11)

LED Bin Grade	Min.	Typ.	Max.
N	27	47	
P	27	47	
Q	27	47	

- R1 value (ohm) for internal LED control, VDD = 5.0V (refer to Figure 12)

LED Bin Grade	Min.	Typ.	Max.
N	47	100	
P	47	100	
Q	47	100	

7.5.2 3.3V Application

- R1 value (ohm) for internal LED control, VDD = VREF = VDD_LED = 3.3V (refer to Figure 13)

LED Bin Grade	Min.	Typ.	Max.
N	22	100	
P	22	100	
Q	22	100	

8. Package Information

8.1 Package Outline Drawing

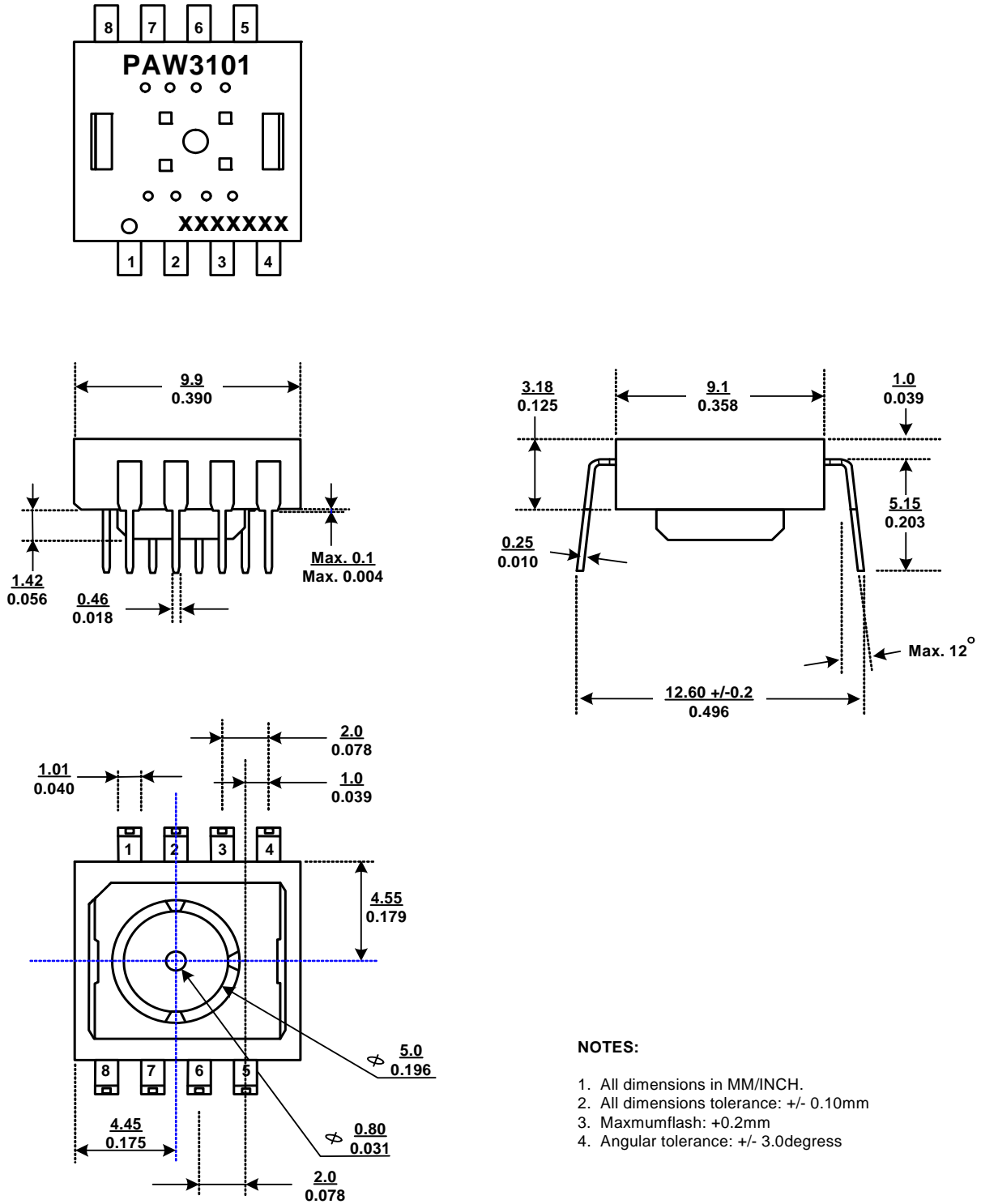
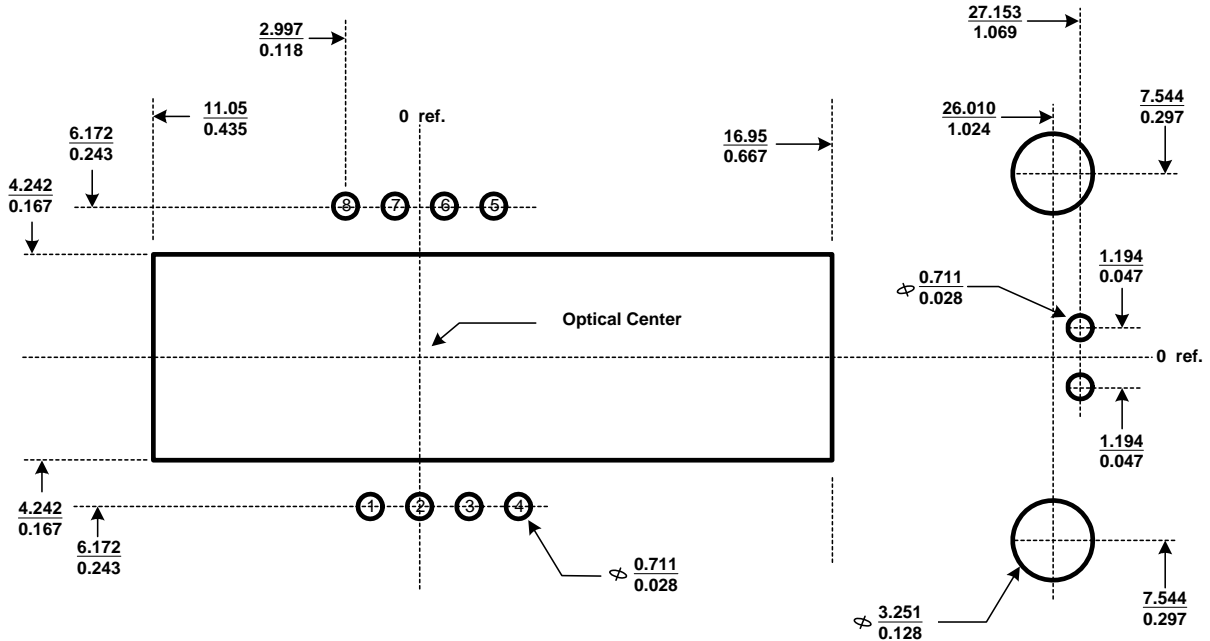

Figure 14. Package Outline Drawing

8.2 Recommended PCB Mechanical Cutouts and Spacing



All Dimensions : mm / inch

Figure 15. Recommended PCB Mechanical Cutouts and Spacing

9. Update History

Version	Update	Date
V2.0	Creation, Preliminary 1 st version	08/11/2006
V2.1	Re-typesetting	09/08/2006
V2.2	Revise words	12/04/2006
V3.0	Add an application for 3.3V operation voltage.	05/09/2008
V3.2	Content revise	05/26/2008

Note: The Part No. of the Mouse Product with Prefix "PAN" shall NOT be made, sold, offered to sell, imported or used in or into USA, Canada, Japan and EU. For "PAN", PixArt has only gained territory-limited patent license from Avago. Avago reserve right to take legal action against our customers who fails to comply the above term. PLEASE NOTE THAT PixArt will NOT defend, indemnify, or provide any assistance to our customers who fail to comply the term. IF YOU DO NOT AGREE THE TERM, PIXART WILL NOT DELIVER "PAN" PRODUCTS TO YOU.