PAW3204 LOW COST WIRELESS MOUSE SENSOR

General Description

The PAW3204DB is a high performance, low power and low cost CMOS process optical mouse sensor with DSP integration chip that serves as a non-mechanical motion estimation engine for implementing a computer wireless mouse.

Features

- ❑ Single power supply
- ❑ Precise optical motion estimation technology
- ❑ Complete 2-D motion sensor
- ❑ Accurate motion estimation over a wide range of surfaces
- ❑ High speed motion detection up to 28 inches/sec
- ❑ High resolution up to 1600 CPI
- ❑ Power saving mode during times of no movement
- ❑ Serial interface for programming and data transfer
- ❑ Built-in Low Power Timer (LPT) for sleep1/sleep2 mode
- ❑ MOTSWK pin to wake up mouse controller when sensor wakes up from sleep mode

Key Specification

Power Supply	Operating voltage 1.73V ~ 1.87V (VDD and VDDA short) 2.5V ~ 2.9V (VDD)
Optical Lens	1:1
Speed	28 inches/sec
Resolution	400/ 500/ 600/ 800/ 1000(Default)/ 1200 / 1600 CPI
Frame Rate	3000 frames/sec
Typical Operating Current	3mA @ Mouse moving (Normal) 300uA @ Mouse not moving (Sleep1) 60uA @ Mouse not moving (Sleep2) 7uA @ Power down mode
Package	Staggered DIP8

Ordering Information

Order Number	I/O	Resolution
PAW3204DB	CMOS output	1000 CPI

1. Pin Configuration

1.1 Pin Description

Pin	Name	Type	Definition
1	OSC_RES	IN	Internal RC oscillator for system clock with external resistor (34.8KΩ for 2.7V application, 36KΩ for 1.8V application)
2	MOTSWK	OUT	Motion detect (active low output, see Section 7 MOTSWK function)
3	SDIO	I/O	Serial interface bi-direction data
4	SCLK	IN	Serial interface clock
5	LED	OUT	LED control
6	VSS	GND	Chip ground
7	VDD	PWR	Power supply (2.5V~2.9V) for internal power regulator, VDDA (1.8V) is the power regulator output. Power supply (1.73V~1.87V) for low power operation voltage
8	VDDA	PWR	Analog/Digital supply voltage (1.8V) Power supply (1.73V~1.87V) for low power operation voltage

1.2 Pin Assignment

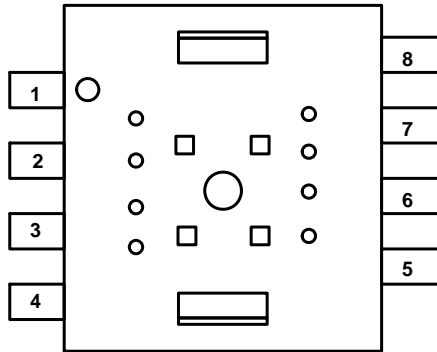

Figure 1. Top View Pinout

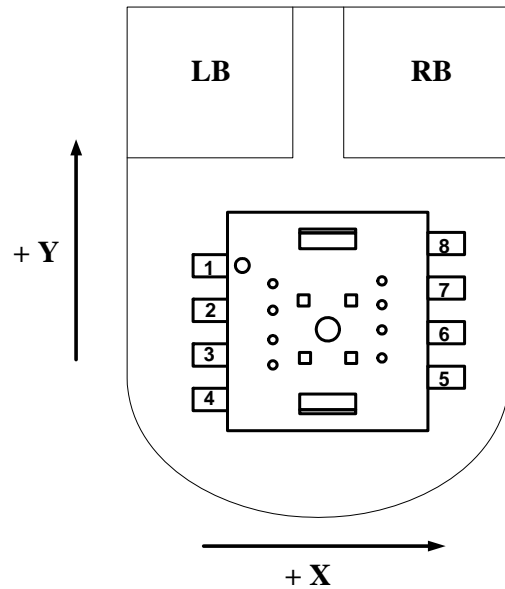

Figure 2. Top View of Mouse

2. Block Diagram and Operation

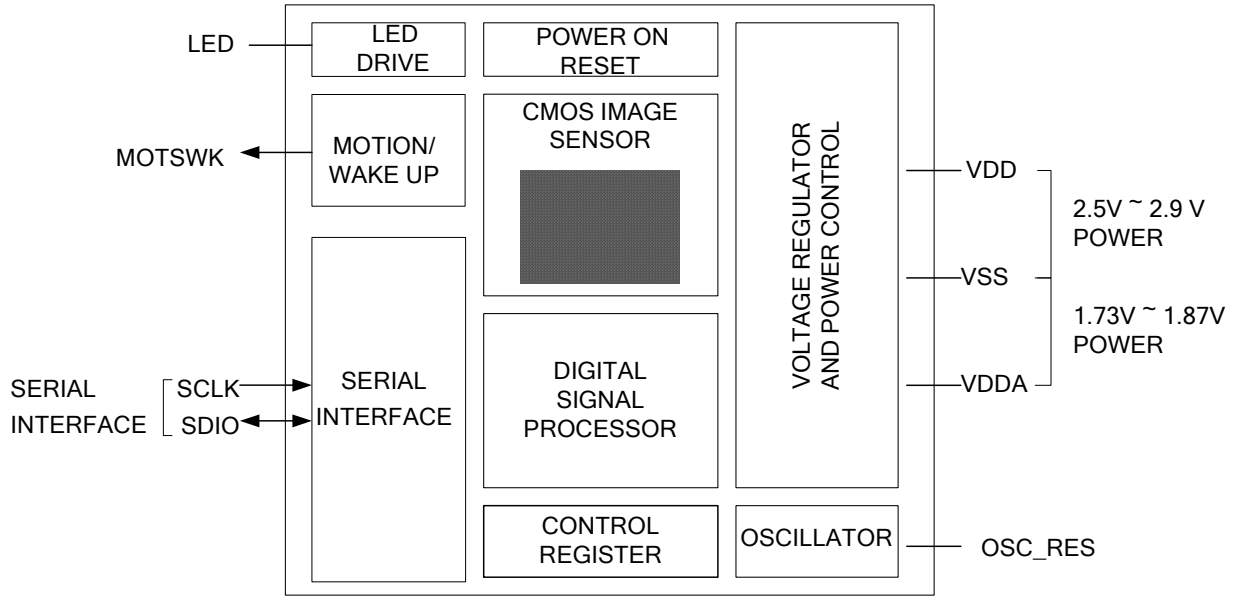

Figure 3. Block Diagram

The PAW3204DB is a high performance, low power and low cost CMOS-process optical mouse sensor with DSP integration chip that serves as a non-mechanical motion estimation engine for implementing a wireless computer mouse. It is based on new optical navigation technology, which measures changes in position by optically acquiring sequential surface images (frames) and mathematically determining the direction and magnitude of movement. The mouse sensor is in an 8-pin optical package. The current X and Y information are available in registers accessed via a serial port. The word "mouse sensor," instead of PAW3204DB, is used in the document.

3. Registers and Operation

The mouse sensor can be programmed through registers, via the serial port, and DSP configuration and motion data can be read from these registers. All registers not listed are reserved, and should never be written by firmware.

3.1 Registers

Address	Name	R/W	Default	Data Type
0x00	Product_ID1	R	0x30	Eight bits[11:4] number with the product identifier
0x01	Product_ID2	R	0x5X	Four bits[3:0] number with the product identifier Reserved[3:0] number is reserved for future use
0x02	Motion_Status	R	-	Bit field
0x03	Delta_X	R	-	Eight bits 2's complement number
0x04	Delta_Y	R	-	Eight bits 2's complement number
0x05	Operation_Mode	R/W	0xB8	Bit field
0x06	Configuration	R/W	0x04	Bit field
0x07	Image_Quality	R	-	Eight bits unsigned integer
0x08	Operation_State	R	-	Bit field
0x09	Write_Protect	R/W	0x00	Bit field
0x0A	Sleep1_Setting	R/W	0x72	Bit field
0x0B	Enter_Time	R/W	0x12	Bit field
0x0C	Sleep2_Setting	R/W	0x92	Bit field
0x0D	Image_Threshold	R/W	0x0A	Eight bits unsigned integer
0x0E	Image_Recognition	R/W	0xE5	Bit field

3.2 Register Descriptions

0x00	Product_ID1							
Bit	7	6	5	4	3	2	1	0
Field	PID[11:4]							
Usage	The value in this register can't change. It can be used to verify the serial communications link is OK.							

0x01		Product_ID2						
Bit	7	6	5	4	3	2	1	0
Field	PID[3:0]			Reserved[3:0]				
Usage	The value in this register can't change. PID[3:0] can be used to verify that the serial communications link is OK. Reserved[3:0] is a value between 0x0 and 0xF, it can't be used to verify that the serial communications.							
0x02		Motion_Status						
Bit	7	6	5	4	3	2	1	0
Field	Motion	Reserved[1:0]		DYOVF	DXOVF	RES[2:0]		
Usage	<p>Motion_Status register allows the user to determine if motion has occurred since the last time it was read. If so, then the user should read <i>Delta_X</i> and <i>Delta_Y</i> registers to get the accumulated motion. It also tells if the motion buffers have overflowed since the last reading. The current resolution is also shown.</p> <p>Reading this register freezes the <i>Delta_X</i> and <i>Delta_Y</i> register values. Read this register before reading the <i>Delta_X</i> and <i>Delta_Y</i> registers. If <i>Delta_X</i> and <i>Delta_Y</i> are not read before the motion register is read a second time, the data in <i>Delta_X</i> and <i>Delta_Y</i> will be lost.</p>							
Notes	Field Name	Description						
	Motion	Motion since last report 0 = No motion (Default) 1 = Motion occurred, data ready for reading in <i>Delta_X</i> and <i>Delta_Y</i> registers						
	Reserved[1:0]	Reserved for future use						
	DYOVF	Motion Delta Y overflow, ΔY buffer has overflowed since last report 0 = No overflow (Default) 1 = Overflow has occurred						
	DXOVF	Motion Delta X overflow, ΔX buffer has overflowed since last report 0 = No overflow (Default) 1 = Overflow has occurred						
	RES[2:0]	Resolution in counts per inch 000 = 400 001 = 500 010 = 600 011 = 800 100 = 1000 (Default) 101 = 1200 110 = 1600						

0x03	Delta_X							
Bit	7	6	5	4	3	2	1	0
Field	X7	X6	X5	X4	X3	X2	X1	X0
Usage	X movement is counted since last report. Absolute value is determined by resolution. Reading clears the register. Report range -128 ~ +127.							
0x04	Delta_Y							
Bit	7	6	5	4	3	2	1	0
Field	Y7	Y6	Y5	Y4	Y3	Y2	Y1	Y0
Usage	Y movement is counted since last report. Absolute value is determined by resolution. Reading clears the register. Report range -128 ~ +127.							

0x05	Operation_Mode							
Bit	7	6	5	4	3	2	1	0
Field	LEDsht_enh	0	1	Slp_enh	Slp2_enh	Slp2mu	Slp1mu	Wakeup
Usage	<p>Operation_Mode register allows the user to change the operation of the mouse sensor. Shown below are the bits, their default values, and optional values.</p> <p>Operation_Mode[4:0]</p> <p>“0xxxx” = Disable sleep mode</p> <p>“10xxx” = Enable sleep mode¹</p> <p>“11xxx” = Enable sleep mode²</p> <p>“11100” = Force enter sleep²³</p> <p>“1x010” = Force enter sleep¹³ (If Slp2_enh is set, the mouse sensor still enter the sleep² automatically.)</p> <p>“1x001” = Force wakeup from sleep mode³</p> <p>Notes:</p> <ol style="list-style-type: none"> 1. Enable sleep mode, but disable automatic entering sleep² mode, that is, only 2 modes will be used, normal mode and sleep¹ mode. After 256 ms ($\pm 20\%$) not moving during normal mode, the mouse sensor will enter sleep¹ mode, and keep on sleep¹ mode until moving is detected or wakeup is asserted. Note that the entering time depends on the setting of <i>Enter_Time</i> register. 2. Enable sleep mode full function, which is 3 modes will be used, normal mode, sleep¹ mode and sleep² mode. After 256 ms ($\pm 20\%$) not moving during normal mode, the mouse sensor will enter sleep¹ mode, and keep on sleep¹ mode until moving is detected or wakeup is asserted. And after 61 sec ($\pm 20\%$) not moving during sleep¹ mode, the mouse sensor will enter sleep² mode, and keep on sleep² mode until detect moving or force wakeup to normal mode. Note that the entering time depends on the setting of <i>Enter_Time</i> register. 3. Only one of these three bits slp2mu_enh, slp1mu_enh, and wakeup can be set to 1 at the same time, others have to be set to 0. After a period of time, the bit, which was set to 1, will be reset to 0 by internal signal. 4. The user can clear <i>Slp_enh/Slp2_enh</i> bit to make the mouse sensor enter normal mode. If the user clears <i>Slp_enh/Slp2_enh</i> bit during normal mode, the mouse sensor will keep its status. If the user clears <i>Slp_enh/Slp2_enh</i> bit during sleep mode, the mouse sensor will enter normal mode after it detect any movement or the user sets <i>Wakeup</i> bit. 							
Notes	Field Name	Description						
	LEDsht_enh	LED shutter enable/disable 0 = Disable 1 = Enable (Default)						
	Bit [6:5]	MUST always be 01						
	Slp_enh	Sleep mode enable/disable 0 = Disable 1 = Enable (Default)						

	Slp2_enh	Automatic enter sleep2 mode enable/disable 0 = Disable 1 = Enable (Default)						
	Slp2mu	Manual enter sleep2 mode, set “1” will enter sleep2 and this bit will be reset to “0”						
	Slp1mu	Manual enter sleep1 mode, set “1” will enter sleep1 and this bit will be reset to “0”						
	Wakeup	Manual wake up from sleep mode, set “1” will enter wakeup and this bit will be reset to “0”						
0x06	Configuration							
Bit	7	6	5	4	3	2	1	0
Field	Reset	MotSwk	0	0	PD_enh	CPI [2:0]		
Usage	<p>The <i>Configuration</i> register allows the user to change the configuration of the sensor. Shown below are the bits, their default values, and optional values.</p> <p>If <i>MotSwk</i> bit is clear, the MOTSWK pin is level-sensitive. The pin level remains low when motion has occurred; in other words, <i>Delta_X</i> and <i>Delta_Y</i> registers has data. The mouse controller can read <i>Motion_Status</i> register, <i>Delta_X</i> register, then <i>Delta_Y</i> register sequentially. After the mouse controller reads all data, <i>Delta_X</i> and <i>Delta_Y</i> are both zero, the pin level will be high (see Section 7).</p> <p>If <i>MotSwk</i> bit is set, the MOTSWK pin is edge-sensitive. The pin will send a pulse and trigger the mouse controller when motion has occurred during the sleep mode. The mouse controller can read <i>Motion_Status</i> register, <i>Delta_X</i> register, then <i>Delta_Y</i> register sequentially (see Section 7).</p>							
Notes	Field Name	Description						
	Reset	Full chip reset 0 = Normal operation mode (Default) 1 = Full chip reset						
	MotSwk	MOTSWK pin output selection (see Section 7) 0 = Motion function output (Default) 1 = SWKINT function output Note that MOTSWK is chip pin, <i>MotSwk</i> is <i>Configuration</i> register bit						
	Bit [5:4]	MUST always be 00						
	PD_enh	Power down mode 0 = Normal operation (Default) 1 = Power down mode						

	CPI[2:0]	Output resolution setting, setting with CPI mode select bit 000 = 400 001 = 500 010 = 600 011 = 800 100 = 1000 (Default) 101 = 1200 110 = 1600
--	----------	--

0x07		Image_Quality						
Bit	7	6	5	4	3	2	1	0
Field	Imgqa[7:0]							
Usage	Image Quality is a quality level of the sensor in the current frame. Report range 0 ~ 255. The default minimum level for normally working is 10. (please see <i>Image_Threshold</i> register)							
Notes	Field Name	Description						
	Imgqa[7:0]	Image quality report range: 0(worst) ~ 255(best).						
0x08		Operation_State						
Bit	7	6	5	4	3	2	1	0
Field	Reserved[3:0]			Slp_state		Op_state[2:0]		
Usage	<i>Operation_State</i> register allows the user to read the operation state of the sensor.							
Notes	Field Name	Description						
	Reserved[3:0]	Reserved for future use						
	Slp_state	Sleep state (If Op_state[2:0] is 100, the Slp_state bit is effective.) 0 = LPT sleep1 1 = LPT sleep2						
	Op_state[2:0]	000 = Normal state 001 = Entry sleep1 processing 010 = Entry sleep2 processing 011 = Reserved for future use 100 = Sleep mode (see Slp_state bit to get sleep state.)						
0x09		Write_Protect						
Bit	7	6	5	4	3	2	1	0
Field	WP[7:0]							
Usage	Write protect for the register 0x0A ~ 0x7F.							
Notes	Field Name	Description						
	WP[7:0]	Write protect enable/disable for the address after 0x09 0x00 = Enable (Default) , register 0x0A ~ 0x7F are read only 0x5A = Disable, register 0x0A ~ 0x7F can be read/written						

0x0A		Sleep1_Setting						
Bit	7	6	5	4	3	2	1	0
Field	Slp1_freq[3:0]				0	0	1	0
Usage	<i>Sleep1_Setting</i> register allows the user to set frequency time for the sleep1 mode.							
Notes	Field Name	Description						
	Slp1_freq[3:0]	Setting frequency time for the sleep1 mode. A scale is 4ms. Relative to its value 0 ~ 15, the frequency time is 4ms ~ 64ms. Default is 32ms. (slp1_freq[3:0] = 0111)						
	Bit [3:0]	MUST always be 0010						
0x0B		Enter_Time						
Bit	7	6	5	4	3	2	1	0
Field	Slp1_etm[3:0]				Slp2_etm[3:0]			
Usage	<i>Enter_Time</i> register allows the user to set enter time for the sleep1 and sleep2 mode.							
Notes	Field Name	Description						
	Slp1_etm[3:0]	Setting sleep1 enter time. A scale is 128ms. Relative to its value 0 ~ 15, the frequency time is 128ms ~ 2048ms. Default is 256ms. (slp1_etm[3:0] = 0001)						
	Slp2_etm[3:0]	Setting sleep2 enter time. A scale is 20480ms. Relative to its value 0 ~ 15, the frequency time is 20480ms ~ 327680ms. Default is 61440ms (about 61 sec). (slp2_etm[3:0] = 0010)						
0x0C		Sleep2_Setting						
Bit	7	6	5	4	3	2	1	0
Field	Slp2_freq[3:0]				0	0	1	0
Usage	<i>Sleep2_Setting</i> register allows the user to set frequency time for the sleep2 mode.							
Notes	Field Name	Description						
	Slp2_freq[3:0]	Setting frequency time for the sleep2 mode. A scale is 32ms. Relative to its value 0 ~ 15, the frequency time is 32ms ~ 512ms. Default is 320ms. (slp2_freq[3:0] = 1001)						
	Bit [3:0]	MUST always be 0010						

0x0D	Image_Threshold							
Bit	7	6	5	4	3	2	1	0
Field	Imgqa_th[7:0]							
Usage	<i>Image_Threshold</i> register allows the user to set image threshold. The mouse sensor calculates data to <i>Delta_X</i> and <i>Delta_Y</i> registers when image quality (please see <i>Image_Quality</i> register) is larger than image threshold.							
Notes	Field Name	Description						
	Imgqa_th[7:0]	Image threshold: 0 (High recognition rate) ~ 255 (Low recognition rate). The minimum level for normally working is 10. Default is 00001010.						
0x0E	Image_Recognition							
Bit	7	6	5	4	3	2	1	0
Field	pk_wt[2:0]			0	Imgqa_df[3:0]			
Usage	<i>Image_Recognition</i> register allows the user to set recognition rate.							
Notes	Field Name	Description						
	pk_wt[2:0]	Peak threshold weighting: 0 (Low recognition rate) ~ 7 (High recognition rate). Default is 111.						
	Bit 4	MUST always be 0						
	Imgqa_df[3:0]	Image qualification threshold difference: 0 (High recognition rate) ~ 15 (Low recognition rate). Default is 1001.						

4. Specifications

4.1 Absolute Maximum Ratings

Stresses above those listed under "Absolute Maximum Rating" may cause permanent damage to the device. These are stress ratings only. Functional operation of this device at these or any other conditions above those indicated in the operational sections of this specification is not implied and exposure to absolute maximum rating conditions for extended periods may affect device reliability.

Symbol	Parameter	Min	Max	Unit	Notes
T _{STG}	Storage Temperature	-40	85	°C	
T _A	Operating Temperature	-15	55	°C	
V _{DC}	DC Supply Voltage	-0.2	V _{dd1} + 0.2	V	
		-0.3	V _{dd2} + 0.3	V	
V _{IN}	DC Input Voltage	-0.3	V _{DC}	V	All I/O pin
	Lead Solder Temp	-	260	°C	For 10 seconds, 1.6mm below seating plane.
ESD		-	2	kV	All pins, human body model MIL 883 Method 3015

4.2 Recommend Operating Condition

Symbol	Parameter	Min.	Typ.	Max.	Unit	Notes
T _A	Operating Temperature	0	-	40	°C	
V _{dd1}	Power Supply Voltage	1.73	1.8	1.87	V	VDDA, VDD short
V _{dd2}		2.5	2.7	2.9		VDD
V _N	Supply Noise	-	-	100	mV	Peak to peak within 0 - 80 MHz
Z	Distance From lens Reference Plane to Surface	2.3	2.4	2.5	mm	Refer to Figure 4.
R	Resolution	400	1000	1600	CPI	
SCLK	Serial Port Clock Frequency	-	-	10	MHz	
FR	Frame Rate	-	3000	-	frames/s	
S	Speed	0	-	28	inches/s	

4.3 AC Operating Condition (1.8V / 2.7V)

Electrical Characteristics over recommended operating conditions. Typical values at 25 °C, $V_{DD} = 2.7\text{ V}$ for 2.7V application and $V_{DD} = V_{DDA} = 1.8\text{ V}$ for 1.8V application.

Symbol	Parameter	Min.	Typ.	Max.	Unit	Notes
t_{PDR}	PD Pulse Register	-	-	666	us	Two frames time maximum after setting <i>PD_enh</i> bit in the <i>Configuration</i> register @3000frame/sec (refer to Figure 11).
t_{PU}	Power Up from $V_{DD}\uparrow$	10	-	30.5	ms	From $V_{DD}\uparrow$ to valid motion signals. 500usec +90 frames.
t_{HOLD}	SDIO Read Hold Time	-	3	-	us	Minimum hold time for valid data (refer to Figure 9).
t_{RESYNC}	Serial Interface RESYNC.	1	-	-	us	@3000 frame/sec (refer to Figure 10)
t_{SIWTT}	Serial Interface Watchdog Timer Timeout	1.7 32 320	-	-	ms	@3000 frame/sec (refer to Figure 10) 1.7ms for normal mode, 32ms ($\pm 20\%$) for sleep1 mode, 320ms ($\pm 20\%$) for sleep2 mode. Note that the value depends on the setting of <i>Sleep1_Setting</i> register and <i>Sleep2_Setting</i> register.
t_{SWKINT}	Sensor Wakeup Interrupt Time	-	160	-	us	
t_r, t_f	Rise and Fall Times: SDIO	-	25, 20	-	ns	$C_L = 30\text{ pF}$
t_r, t_f	Rise and Fall Times: ILED	-	30, 10	-	ns	

4.4 DC Electrical Characteristics (1.8V)

Electrical Characteristics over recommended operating conditions. Typical values at 25 °C, $V_{DD} = V_{DDA} = 1.8\text{ V}$

Symbol	Parameter	Min.	Typ.	Max.	Unit	
Type: Power						
I_{DDN}	Supply Current Mouse Moving (Normal)	-	3	-	mA	
I_{DDS1}	Supply Current Mouse Not Moving (Sleep1)	-	300	-	uA	
I_{DDS2}	Supply Current Mouse Not Moving (Sleep2)	-	60	-	uA	
I_{DDPD}	Supply Current (Power Down)	-	7	-	uA	
Type: SCLK, SDIO						
V_{IH}	Input Voltage HIGH	1.45	-	-	V	
V_{IL}	Input Voltage LOW	-	-	0.4	V	
V_{OH}	Output Voltage HIGH	1.4	-	-	V	@ $I_{OH} = 2\text{mA}$
V_{OL}	Output Voltage LOW	-	-	0.4	V	@ $I_{OL} = 2\text{mA}$
Type: LED						
V_{OL}	Output Voltage LOW	-	-	380	mV	@ $I_{OL} = 25\text{mA}$

4.5 DC Electrical Characteristics (2.7V)

Electrical Characteristics over recommended operating conditions. Typical values at 25 °C, $V_{DD} = 2.7\text{ V}$

Symbol	Parameter	Min.	Typ.	Max.	Unit	
Type: Power						
I_{DDN}	Supply Current Mouse Moving (Normal)	-	3	-	mA	
I_{DDS1}	Supply Current Mouse Not Moving (Sleep1)	-	300	-	uA	
I_{DDS2}	Supply Current Mouse Not Moving (Sleep2)	-	60	-	uA	
I_{DDPD}	Supply Current (Power Down)	-	7	-	uA	
Type: SCLK, SDIO						
V_{IH}	Input Voltage HIGH	2.0	-	-	V	
V_{IL}	Input Voltage LOW	-	-	0.9	V	
V_{OH}	Output Voltage HIGH	2.3	-	-	V	@ $I_{OH} = 2\text{mA}$
V_{OL}	Output Voltage LOW	-	-	0.4	V	@ $I_{OL} = 2\text{mA}$
Type: LED						
V_{OL}	Output Voltage LOW	-	-	380	mV	@ $I_{OL} = 25\text{mA}$

5. Z and 2D/3D Assembly

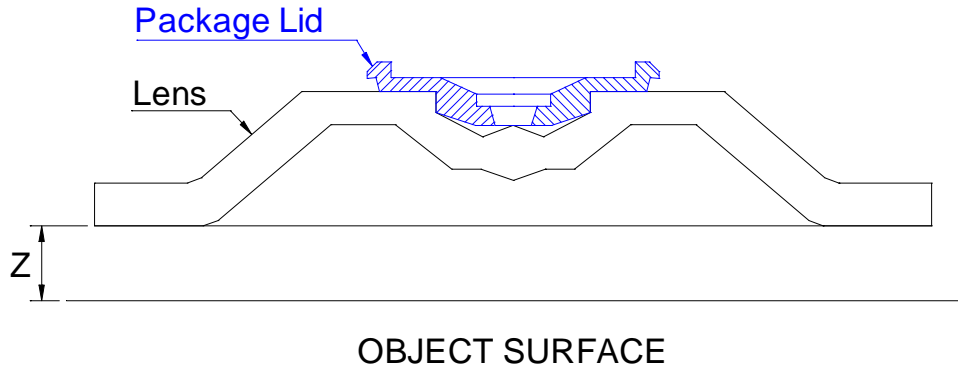

Figure 4. Distance from Lens Reference Plane to Surface

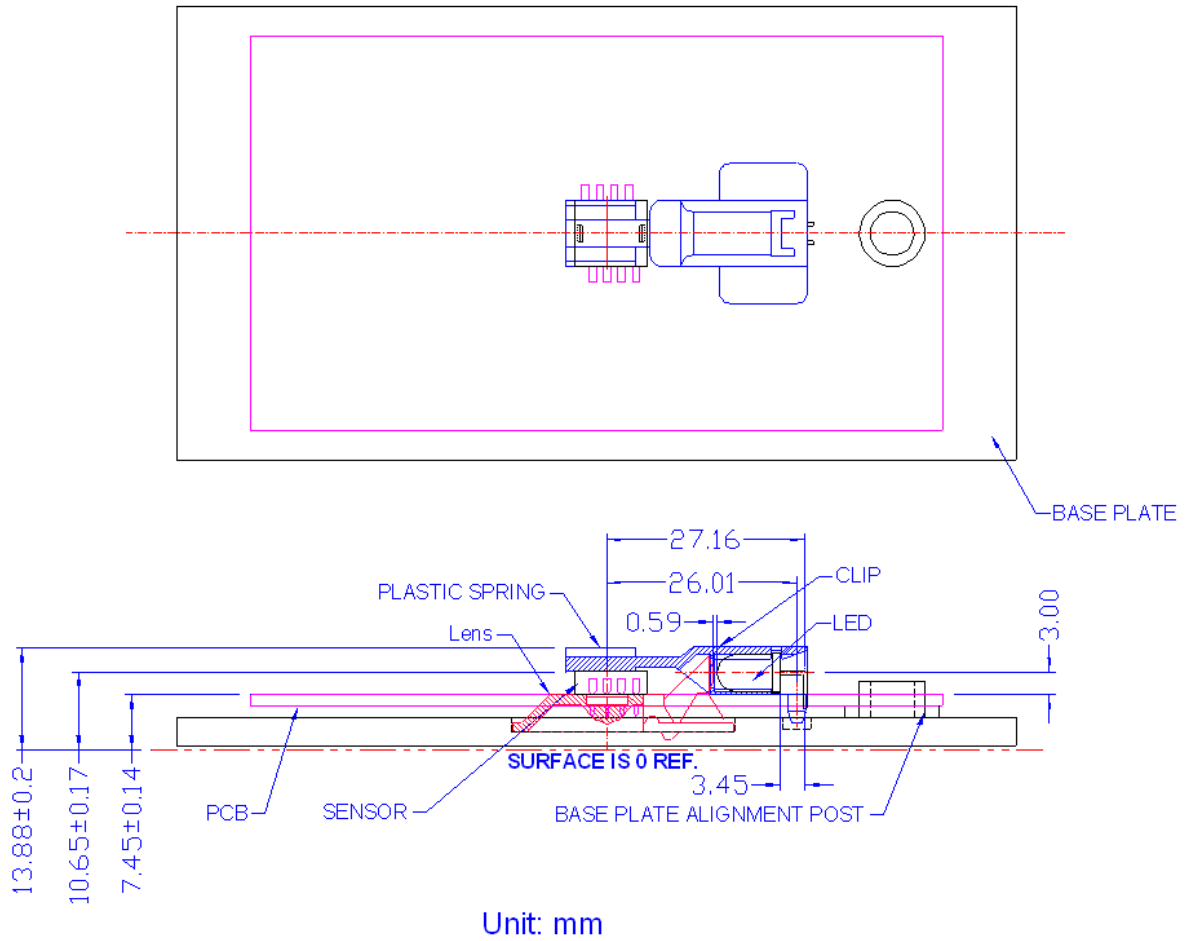

Figure 5. 2D Assembly

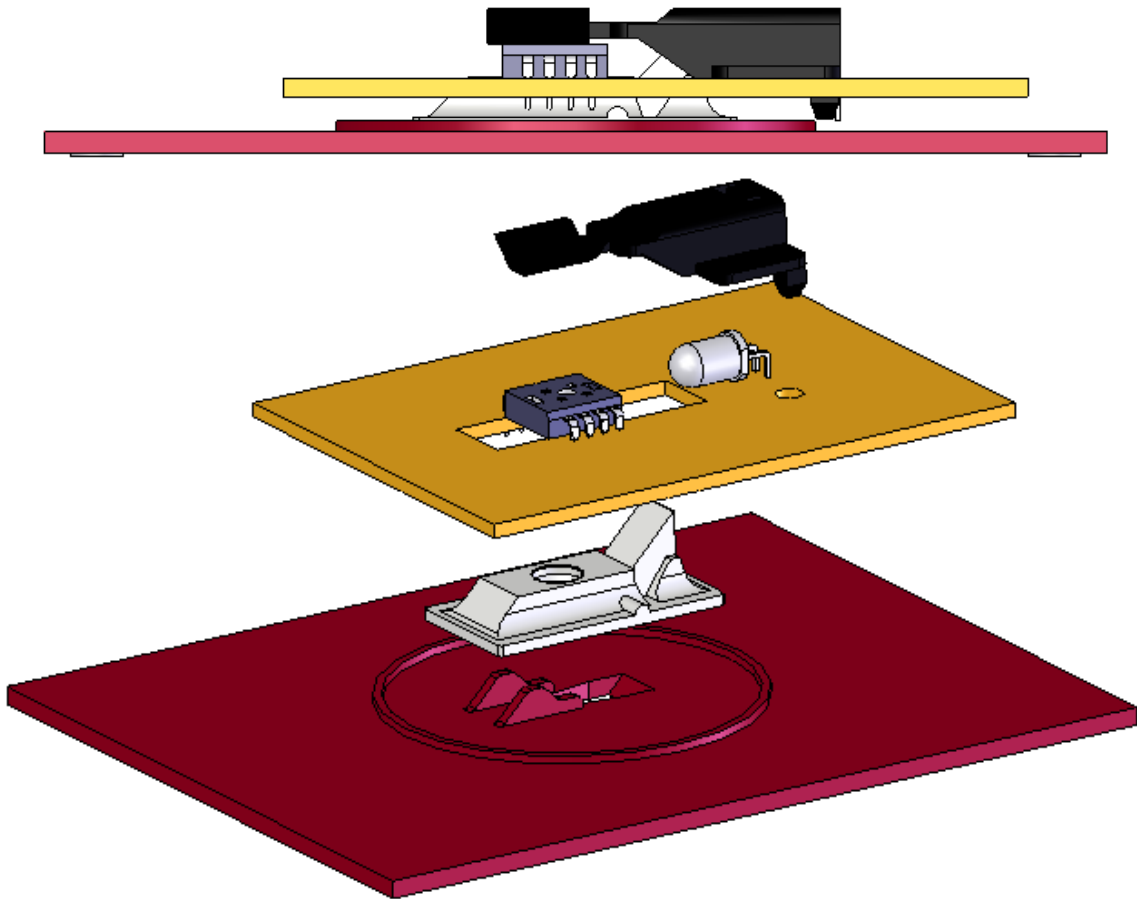

Figure 6. 3D Assembly for Mounting Instructions

6. Serial Interface

The synchronous serial port is used to set and read parameters in the mouse sensor.

SCLK: The serial clock line. It is always generated by the mouse controller.

SDIO: The serial data line is used to write and read data.

6.1 Transmission Protocol

The transmission protocol is a two-wire link, half duplex protocol between the micro-controller and the mouse sensor. All data changes on SDIO are initiated by the falling edge on SCLK. The mouse controller always initiates communication; the mouse sensor never initiates data transfers.

The transmission protocol consists of the two operation modes:

- Write Operation.
- Read Operation.

Both of the two operation modes consist of two bytes. The first byte contains the address (seven bits) and has a bit 7 as its MSB to indicate data direction. The second byte contains the data.

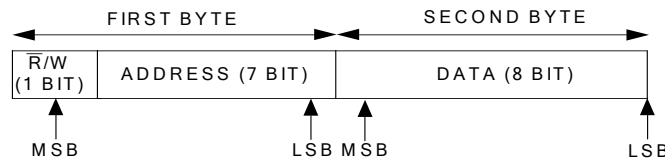

Figure 7. Transmission Protocol

6.1.1 Write Operation

A write operation, which means that data is going from the mouse controller to the mouse sensor, is always initiated by the mouse controller and consists of two bytes. The first byte contains the address (seven bits) and has a “1” as its MSB to indicate data direction. The second byte contains the data. The transfer is synchronized by SCLK. The mouse controller changes SDIO on falling edges of SCLK. The mouse sensor reads SDIO on rising edges of SCLK.

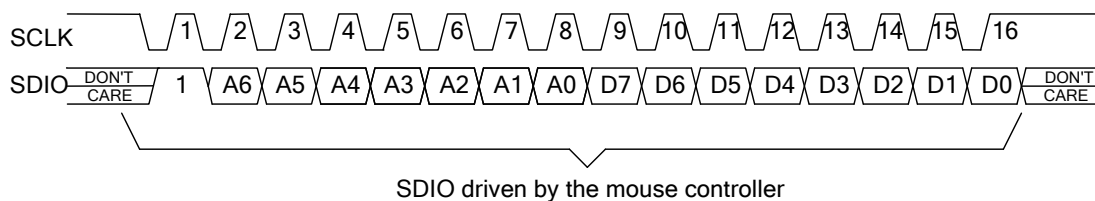
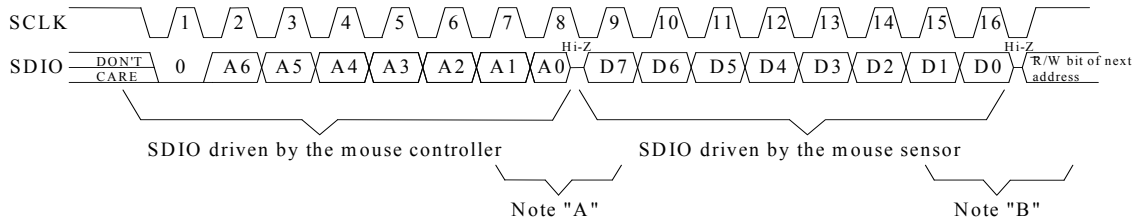

Figure 8. Write Operation

6.1.2 Read Operation

A read operation, which means that data is going from the mouse sensor to the mouse controller, is always initiated by the mouse controller and consists of two bytes. The first byte contains the address, is written by the mouse controller, and has a “0” as its MSB to indicate data direction. The second byte contains the data and is driven by the mouse sensor. The transfer is synchronized by SCLK. SDIO is changed on falling edges of SCLK and read on every rising edge of SCLK. The mouse controller must go to a high Z state after the last address data bit. The mouse sensor will go to the high Z state after the last data bit.



- Note "A" 1. The mouse controller sends address to the mouse sensor.
 2. The mouse controller releases and set SDIO to Hi-Z after the last address bit.

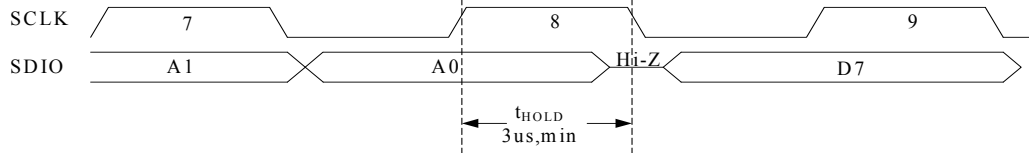

- Note "B" 1. The mouse sensor sends data to the mouse controller .
 2. The mouse sensor releases and set SDIO to Hi-Z after the last data bit.

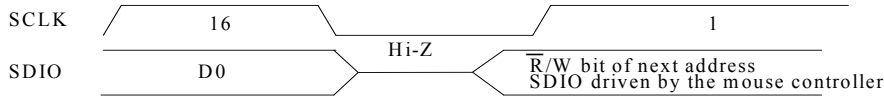

Figure 9. Read Operation

6.2 Re-Synchronous Serial Interface

If the mouse controller and the mouse sensor get out of synchronization, then the data either written or read from the registers will be incorrect. In such a case, an easy way to solve this condition is to toggle the SCLK line from high to low for least t_{RESYNC} , and then MUST toggle it from low to high to wait at least t_{SIWTT} to reach re-synchronous the serial port. This method is called by “watchdog timer timeout”. The mouse sensor will reset the serial port without resetting the registers and be prepared for the beginning of a new transmission.

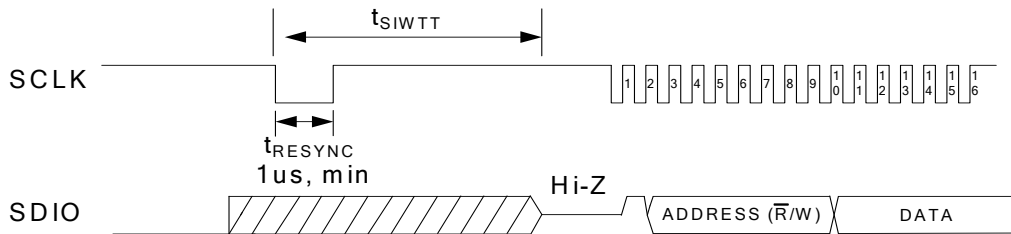

Figure 10. Re-synchronous Serial Interface Using Watchdog Timer Timeout

Note that this function is disabled when the mouse sensor is in the power down mode. If the user uses this function during the power down mode, it will get out of synchronization. The mouse sensor and the mouse controller also might get out of synchronization due to following conditions.

- Power On Problem - The problem occurs if the mouse sensor powers up before the mouse controller sets the SCLK and SDIO lines to be output. The mouse sensor and the mouse controller might get out of synchronization due to power on problem. An easy way to solve this is to use “watchdog timer timeout”.
- ESD Events - The mouse sensor and the mouse controller might get out of synchronization due to ESD events. An easy way to solve this is to use “watchdog timer timeout”.

6.3 Collision Detection on SDIO

The only time that the mouse sensor drives the SDIO line is during a READ operation. To avoid data collisions, the mouse controller should release SDIO before the falling edge of SCLK after the last address bit. The mouse sensor begins to drive SDIO after the next falling edge of SCLK. The mouse sensor releases SDIO of the rising SCLK edge after the last data bit. The mouse controller can begin driving SDIO any time after that. In order to maintain low power consumption in normal operation or when the PD pin is pulled high, the mouse controller should not leave SDIO floating until the next transmission (although that will not cause any communication difficulties).

6.4 Power Down Mode

The mouse sensor can be placed in a power-down mode by setting *PD_enh* bit in the *Configuration* register via a serial port write operation. After setting the *Configuration* register, wait at most 2 frames times. To get the chip out of the power down mode, clear *PD_enh* bit in the *Configuration* register via a serial port write operation. In the power down mode, the serial interface watchdog timer (see Section 6.2) is not available. But, the serial interface still can read/write normally. For an accurate report after leave the power down mode, wait about 3ms before the mouse controller is able to issue any write/read operation to the mouse sensor.

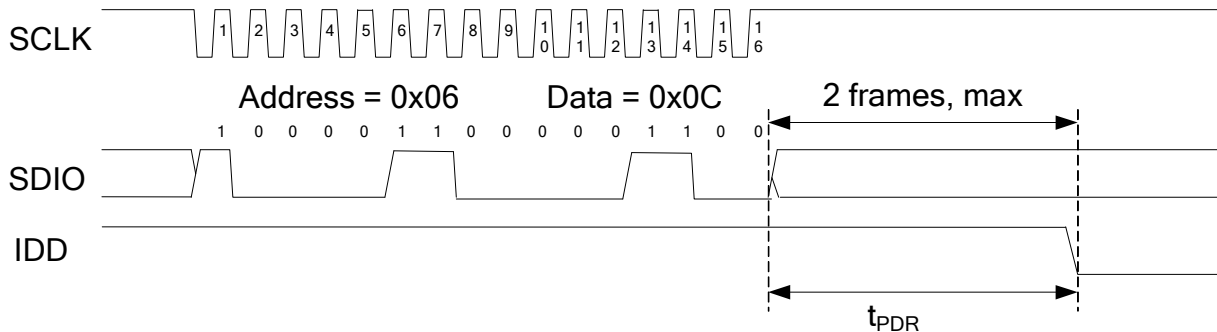

Figure 11. Power-down Configuration Register Writing Operation

6.5 Error Detection

1. The mouse controller can verify success of write operations by issuing a read command to the same address and comparing written data to read data.
2. The mouse controller can verify the synchronization of the serial port by periodically reading the product ID register

7. MOTSWK function

7.1 Motion function

To use Motion function, the *MotSwk* bit in the *Configuration* register must be set to zero. Motion is used to monitor if the mouse sensor has finished sending X-Y movement data to the mouse controller. If all movement data are not read, MOTSWK pin level will remain low. After the mouse controller reads all movement data from the mouse sensor, the mouse sensor will set MOTSWK pin level to high.

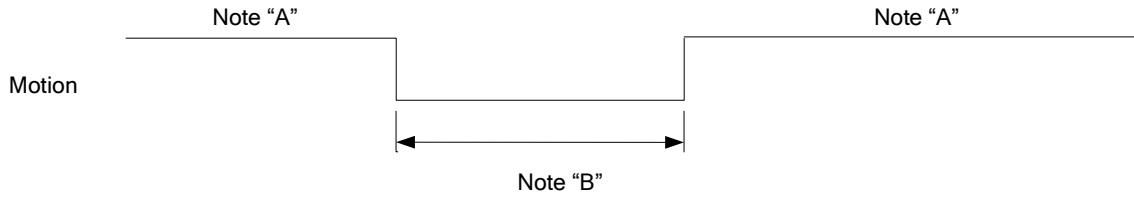

Note "A": *Delta_X* / *Delta_Y* are equal to 0.

Note "B": *Delta_X* / *Delta_Y* are not equal to 0.

Figure 12. Motion function

7.2 SWKINT function

To use SWKINT function, the *MotSwk* bit in the *Configuration* register must be set to one. SWKINT works when the mouse sensor is in the sleep mode and the mouse controller is also in the sleep mode. If the mouse sensor detects any motion occurrence at this moment, the mouse sensor will wake the mouse controller up promptly via MOTSWK pin. The mouse sensor will trigger the mouse controller at the rising/falling edge of MOTSWK pin.

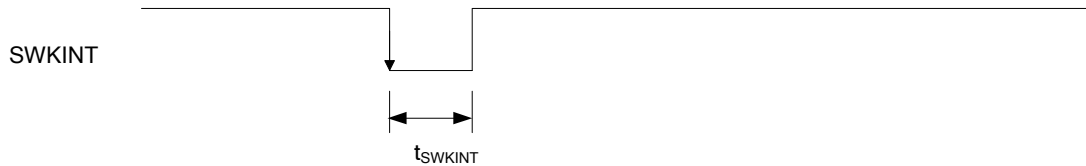

Figure 13. SWKINT function

8. Referencing Application Circuit

8.1 Power Supply at 2.7V Application Circuit (with Red LED, 2.4GHz Transceiver)

#1. Battery Power Circuit

DC/DC Converter

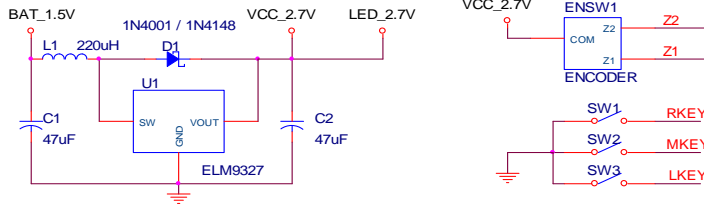

#2. MCU Circuit

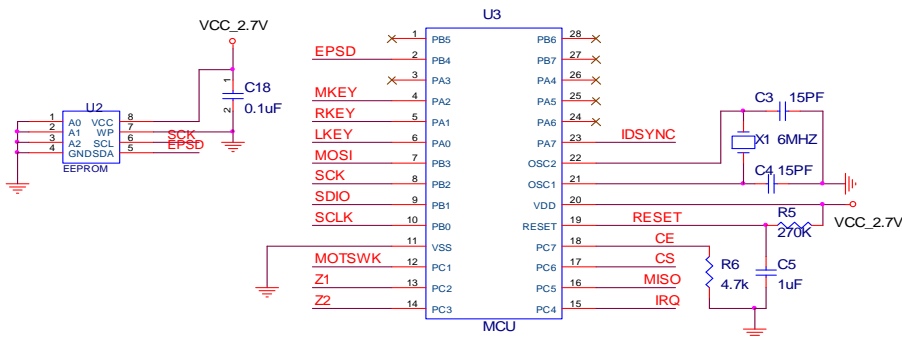

PAW3204 external resistor notes
 *Note that 2.7V application, R4 use 34.8K ohm +/- 1%
 *Note that 1.8V application, R4 use 36K ohm +/- 1%

#3. Sensor Circuit

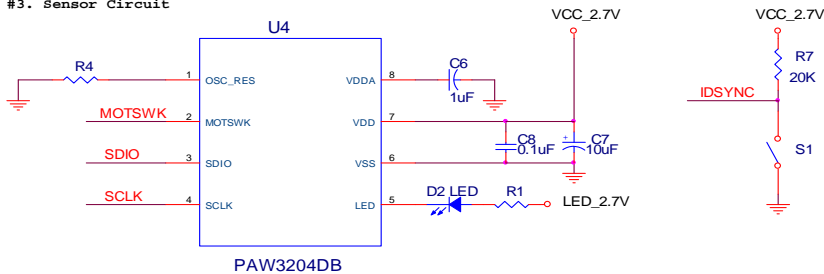

#4. RF TX Circuit

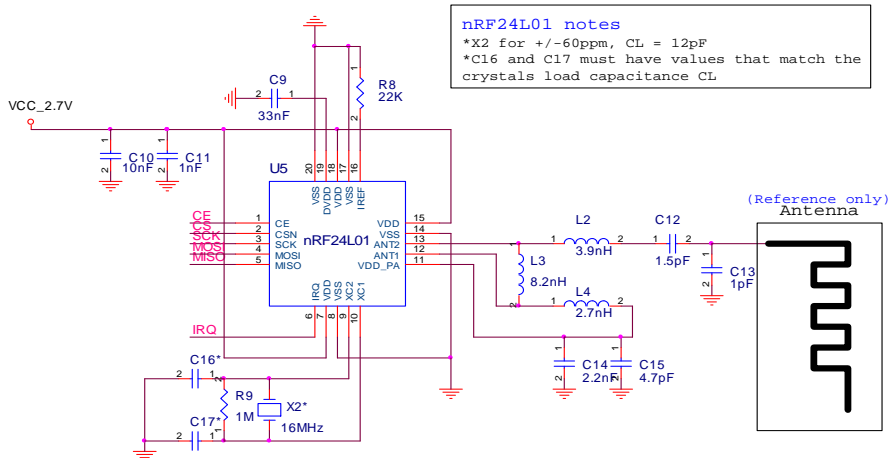

Figure 14. Application Circuit for 2.7V (with Red LED)

8.2 Reference Application for RF Receiver Using 2.4GHz Transceiver

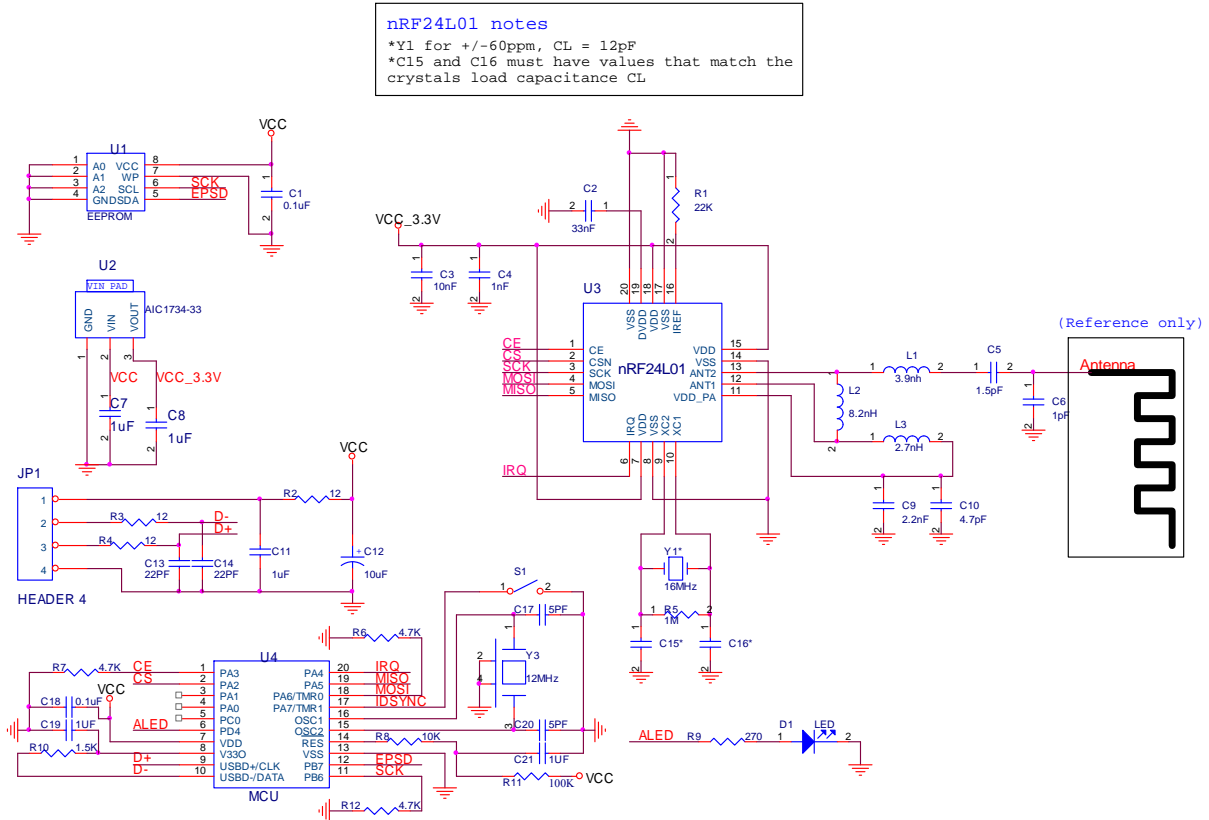

Figure 15. Application Circuit for RF Receive Using 2.4GHz Transceiver

8.3 PCB Layout Consideration

Caps for pins 7, 8 must have trace lengths less than 5mm

8.4 Recommended Value for R1

8.4.1 Using Red LED for 2.7V

- Radiometric intensity of red LED

Bin limits (mW/Sr at 20mA). Recommended using Everlight 7343USRC/S1029-1 LED.

LED Bin Grade	Min.	Typ.	Max.
Q	21.2	-	25.4

Note: Tolerance for each bin will be $\pm 15\%$

Suggested R1(ohm):

Red LED Bin Grade	Min.	Typ.	Max.
Q	6.8	-	22

8.4.2 Summary

Light Source	LED Bin Grade	V_{LED}	R1		
			Min.	Typ.	Max.
Red LED	Q	2.7	6.8	-	22

9. Optical Criterion

9.1 Recommended Red LED Angle Criterion

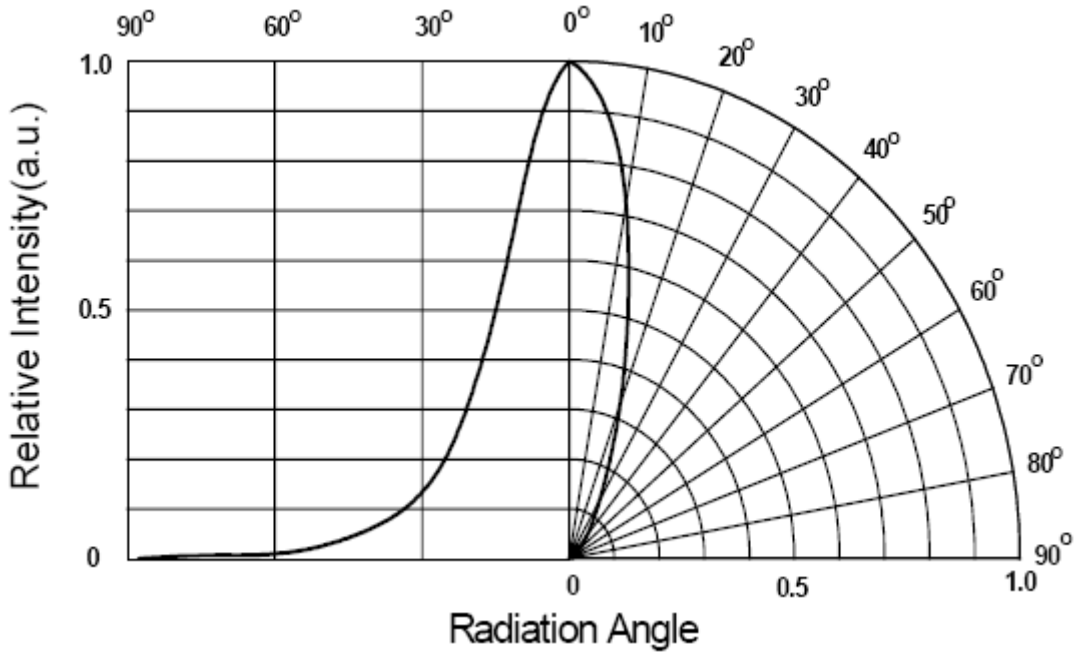

Figure 16. Radiation Characteristics

LED Viewing Angle	Min.	Typ.	Max.
$2\theta_{1/2}$	24	30	36

- Recommended using Chang-Yu LED goniophotometer V110 to measure the LED viewing angle.

9.2 Recommended Value for Optical Power

- In order to tracking performance of PAW3204DB are acceptable and lower power consumption of LED, PixArt recommended value for optical power. By selecting LED bin grade or changing R1 value, optical power can be adjust. Optical power is measured from base plate rectangle hole. LED is DC mode. (Please see optical power measurement method AP note). Recommended using ADCMT power meter 8230E to measure the optical power.

Parameter	Min.	Max.	Unit
Optical Power	1632.5	-	uW

10. Package Information

10.1 Package Outline Drawing

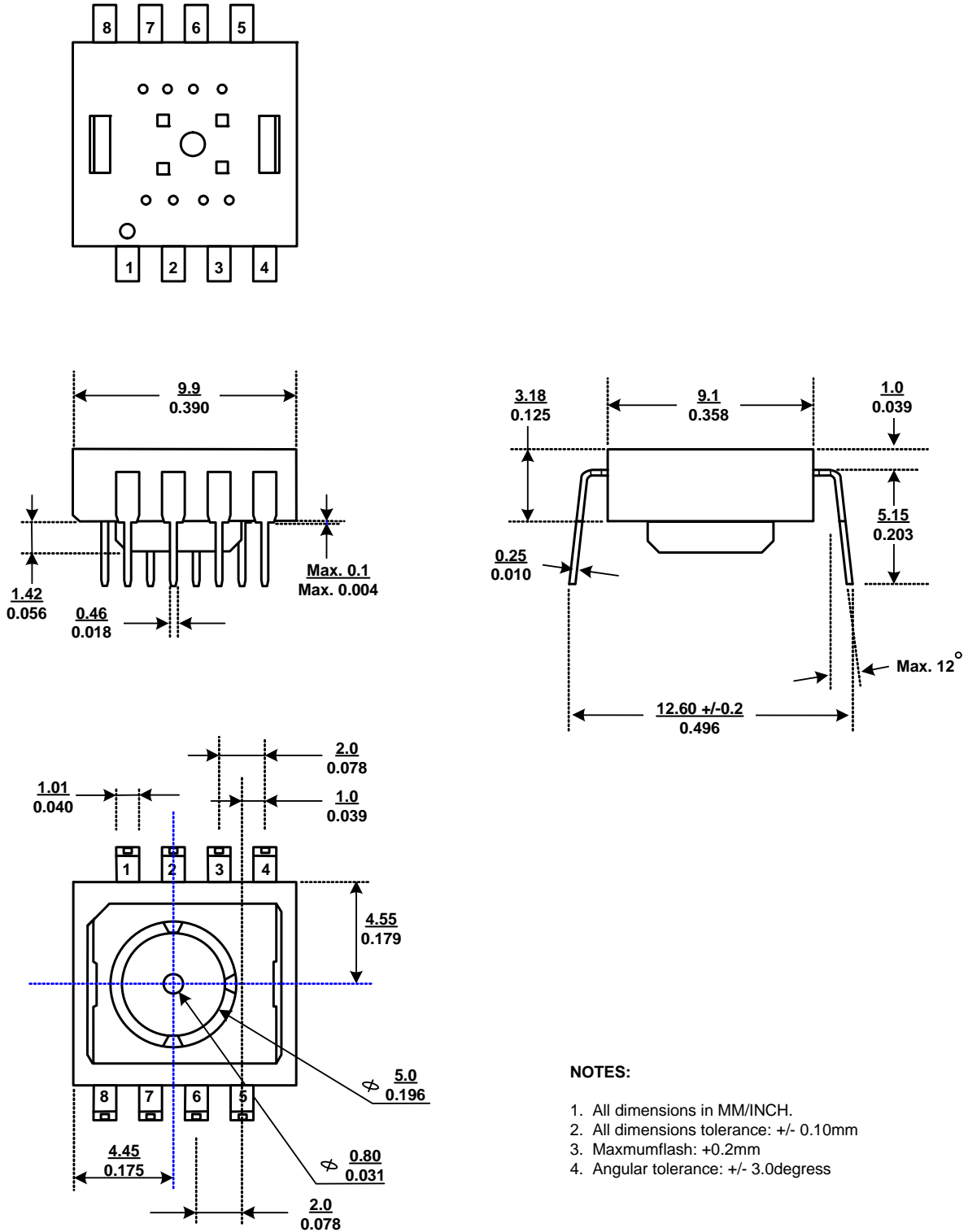

- NOTES:**
1. All dimensions in MM/INCH.
 2. All dimensions tolerance: +/- 0.10mm
 3. Maximum flash: +0.2mm
 4. Angular tolerance: +/- 3.0degrees

Figure 17. Package Outline Drawing

10.2 Recommended PCB Mechanical Cutouts and Spacing

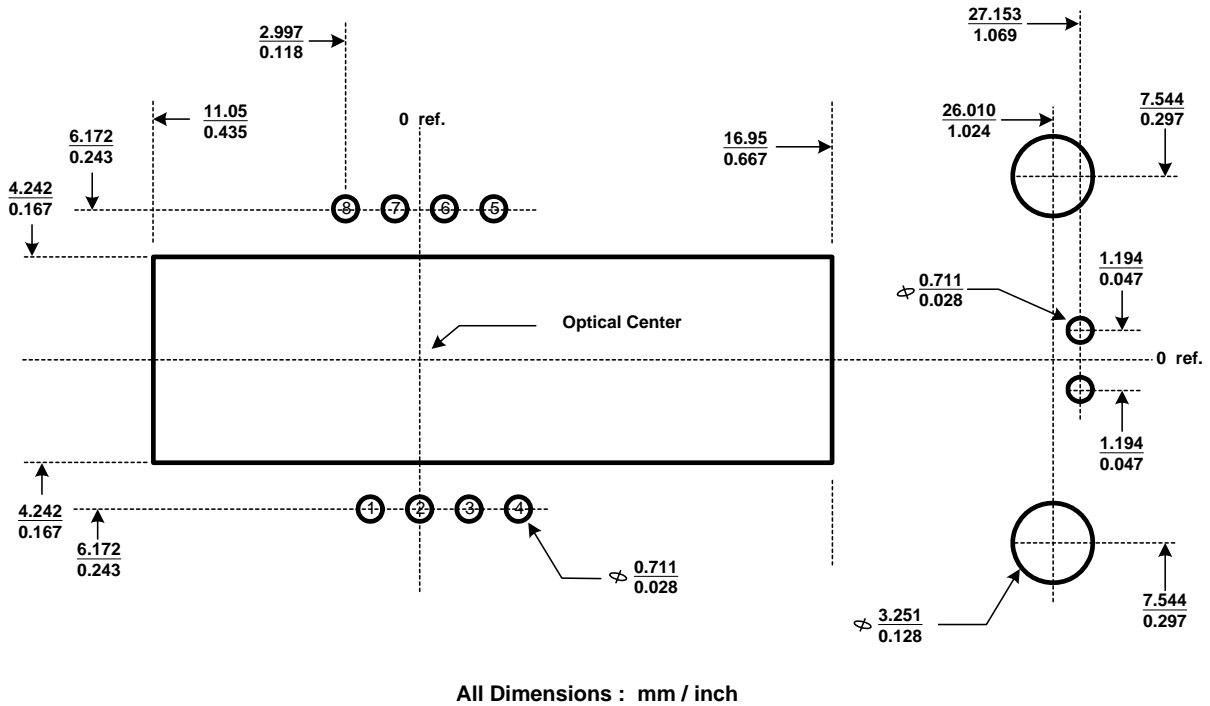

Figure 18. Recommended PCB Mechanical Cutouts and Spacing

11. Update History

Version	Update	Date
V1.0	Creation, Preliminary 1 st version	09/05/2007
V3.1	Content revise, Ch8.1, Ch8.2, Ch8.3, and Ch8.4	04/22/2008
V4.0	Added Ch9	12/07/2009

Note: The Part No. of the Mouse Product with Prefix "PAN" shall NOT be made, sold, offered to sell, imported or used in or into USA, Canada, Japan and EU. For "PAN", PixArt has only gained territory-limited patent license from Avago. Avago reserve right to take legal action against our customers who fails to comply the above term. PLEASE NOTE THAT PixArt will NOT defend, indemnify, or provide any assistance to our customers who fail to comply the term. IF YOU DO NOT AGREE THE TERM, PIXART WILL NOT DELIVER "PAN" PRODUCTS TO YOU.