

PAW3504 PURE USB OPTICAL MOUSE SINGLE CHIP
General Description

The PAW3504 is a CMOS process optical mouse sensor single chip with USB interface that serves as a non-mechanical motion estimation engine for implementing a computer mouse.

Features

- USB interface**
- Single power supply**
- Optical motion estimation technology**
- Complete 2-D motion sensor**
- Accurate motion estimation over a wide range of surfaces**
- High speed motion detection up to 28 inches/sec**
- Power saving mode during times of no movement**
- Supports three buttons (R, M, L) and three axes (X, Y, Z) output**
- Z-axis support mechanical input (Z/2)**
- Reduce jiggle happen**
- USB spec.**
 - **Complete Universal Serial Bus specs V1.1 compatibility**
 - **Complete USB HID specs V1.11 compatibility**
 - **Integrated USB transceiver and 1.5Mbps USB serial interface engine**

Key Specification

Power Supply	Wide operating supply range 4.25V ~ 5.5V
Interface	USB
Optical Lens	1:1
System Clock	24.000 MHz
Speed	28 inches/sec
Acceleration	20g
Resolution	800 CPI
Frame Rate	3000 frames/sec
Operating Current	10mA @Mouse moving (Normal) 5mA @Mouse not moving (Sleep) 480uA @USB suspend (Suspend)
Package	Shrunk DIP14

Ordering Information

Part Number	CPI
PAW3504DLY	800

1. Pin Configuration

1.1 Pin Description

Pin #	Name	Type	Definition
1	OSCIN	IN	Oscillator input, connected to resonator or resistor
2	BL	IN	Button left key input, normal pull-high (50k), press connect to low
3	LED	OUT	LED control
4	VDDQ	BYPASS	I/O voltage reference
5	VSS	GND	Chip ground
6	VDD5V	PWR	Chip power VDD, 5.0V
7	VDDA	BYPASS	Analog voltage reference
8	D+	I/O	USB D+
9	D-	I/O	USB D-
10	BR	IN	Button right key input, normal pull-high (50k), press connect to low
11	BM	IN	Button middle key input, normal pull-high (50k), press connect to low
12	Z2	IN	Z axis, support mechanical scroller input
13	Z1	IN	Z axis, support mechanical scroller input
14	OSCOUT	OUT	Oscillator output, connected to resonator

1.2 Pin Assignment

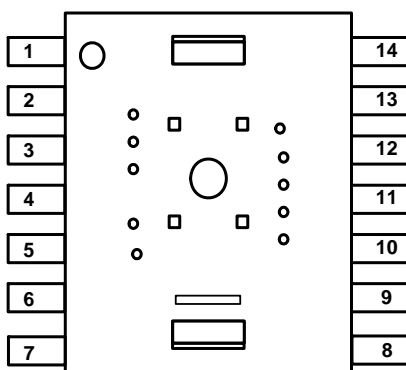

Figure 1. Top View Pinout

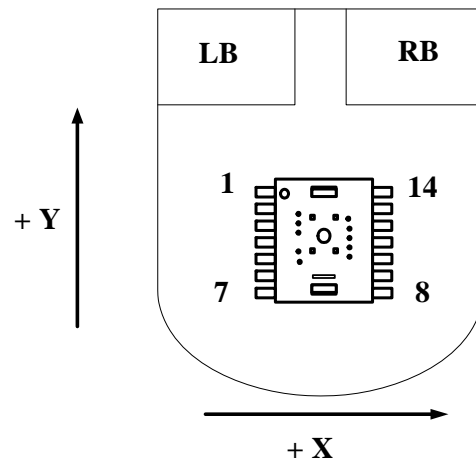

Figure 2. Top View of Mouse

2. Block Diagram and Operation

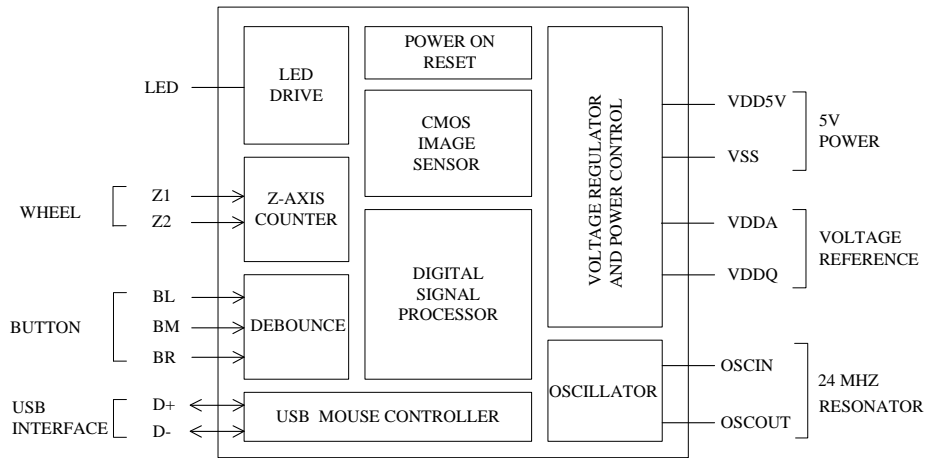

Figure 3. Block Diagram

The PAW3504 supports X, Y, Z three axes, and L, R, M three buttons under USB mode. It is a CMOS process optical mouse sensor single chip with USB interface that serves as a non-mechanical motion estimation engine for implementing a computer mouse.

The PAW3504 is in a 14-pin optical package and comes with the resolution of 800 counts per inch (CPI) and the rate of motion up to 28 inches per second. It includes USB interface so that no mouse controller is needed to interface through USB. The PAW3504 can receive command and echo status or data format, both complete Universal Serial Bus[®] spec V1.1 and USB HID spec V1.11 compatibility. It is also a cost effective solution to support USB Mouse.

3. Specifications

3.1 Absolute Maximum Ratings

Exposure to absolute maximum rating may affect device reliability.

Symbol	Parameter	Min.	Max.	Unit	Notes
T _{STG}	Storage Temperature	-40	85	°C	
TA	Operating Temperature	-15	55	°C	
	Lead Solder Temp		260	°C	For 10 seconds, 1.6 mm below seating plane.
ESD			2	kV	All pins, human body model MIL 883 Method 3015
V _{DC}	DC Supply Voltage	-0.5	5.5	V	
V _{IN}	DC Input Voltage	-0.5	5.5	V	Z1, Z2
		-0.5	4.0	V	BL, BR, BM

3.2 Recommend Operating Condition

Symbol	Parameter	Min.	Typ.	Max.	Unit	Notes
T _A	Operating Temperature	0		40	°C	
V _{DD}	Power Supply Voltage	4.25	5.0	5.5	V	
V _N	Supply Noise			100	mV	Peak to peak within 0 - 80 MHz
Z	Distance from Lens Reference Plane to Surface	2.3	2.4	2.5	mm	Refer to Figure 4.
R	Resolution	400	800		CPI	
A	Acceleration			20	g	
F _{CLK}	Clock Frequency		24		MHz	
FR	Frame Rate		3000		frames/sec	
S	Speed	0	20	28	inches/sec	28 inches/sec @400CPI 20 inches/sec @800CPI

3.3 AC Electrical Characteristics

Electrical characteristics over recommended operating conditions. Typical values at 25 °C, V_{DD} = 5.0 V, F_{CLK} = 24 MHz

Symbol	Parameters	Min.	Typ.	Max.	Unit	Notes
T _b	Mouse Button Debounce Time	-	10.24	-	ms	
T _z	Mouse Z Debounce Time	-	1.024	-	ms	

3.4 DC Electrical Characteristics

Electrical characteristics over recommended operating conditions. Typical values at 25 °C, V_{DD} =5.0 V, F_{CLK}=24 MHz.

Symbol	Parameter	Min.	Typ.	Max.	Unit	Notes
Type: USB Mouse PWR						
I _{DD}	Supply Current Mouse moving (Normal)	-	10	-	mA	
I _{DD}	Supply Current Mouse not moving (Sleep)	-	5	-	mA	
I _{DD}	Supply Current USB suspend current	-	-	480	uA	
Type: BL, BM, BR						
R _{PH}	Internal Pull Up Resistance	-	50	-	Kohm	
V _{IH}	Input High Voltage	2.0	-	-	V	
V _{IL}	Input Low Voltage	-	-	0.8	V	
Type: Z1, Z2						
R _{PD}	Internal Pull Down Resistance	-	50	-	Kohm	
V _{IH}	Input High Voltage	2.0	-	-	V	
V _{IL}	Input Low Voltage	-	-	0.8	V	
Type: USB DP, DN						
R _{PH}	Internal Pull Up Resistance (USB Spec 5%)	-20%	1.5	+20%	Kohm	
Type: OSCIN						
V _{IH}	Input High Voltage	2.1	-	-	V	When driving from an external source
V _{IL}	Input Low Voltage	-	-	0.5	V	When driving from an external source
Type: VDDQ						
VDDQ	I/O Voltage Reference	-	3.3	-	V	

3.5 Button and Z-Wheel Debounce Timing

Buttons and Z wheel of PAW3504DLY include detect and debounce function which are hardware implement. When press button input signals need keeping low level up to 9.216ms. Button function just can catch data otherwise debounce function will judge it is bounce issue. When scroll Z wheel input signals need keeping turning level up to 0.896ms. Z wheel function just can catch data otherwise debounce function will judge it is bounce issue. And the hardware sample rate is 2us so if bounce time is less than 2us the debounce function will ignore it. Following the below specifications Buttons and Z wheel will work normally.

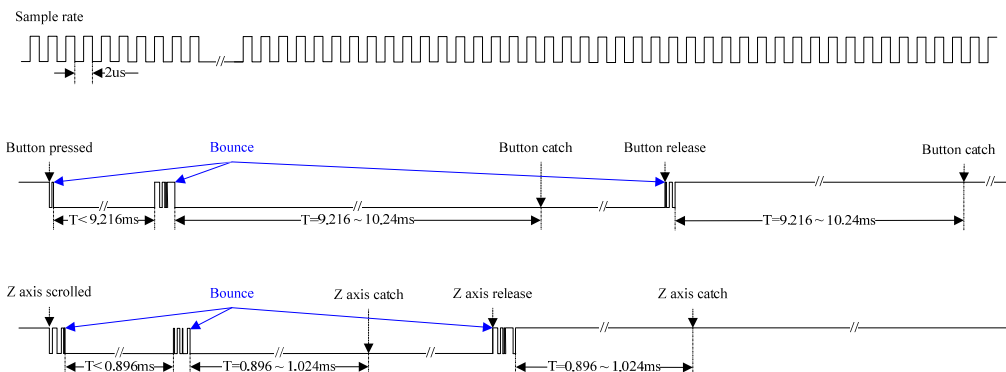

3.6 Z-axis Waveform

Scroll down sequence

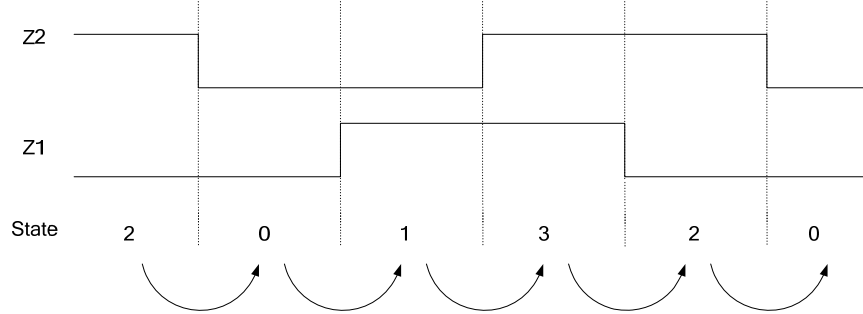

Scroll up sequence

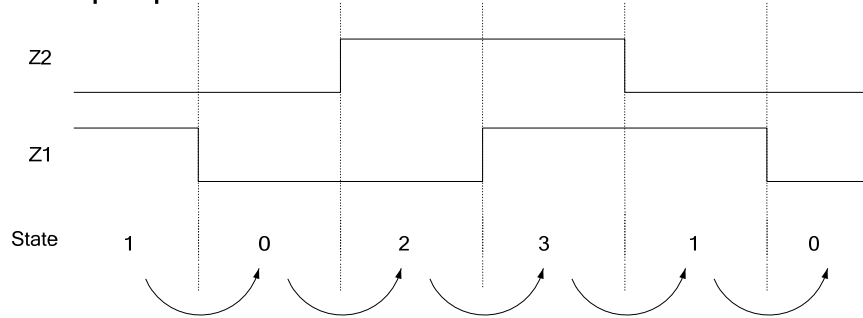

STATE	Z-axis input	
	Z2	Z1
0	0	0
1	0	1
2	1	0
3	1	1

Figure 4. Z-axis Waveform

4. Z and 2D/3D Assembly

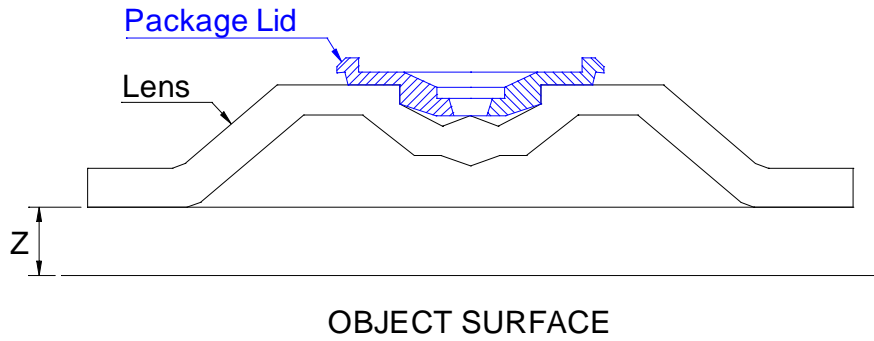

Figure 5. Distance from Lens Reference Plane to Surface

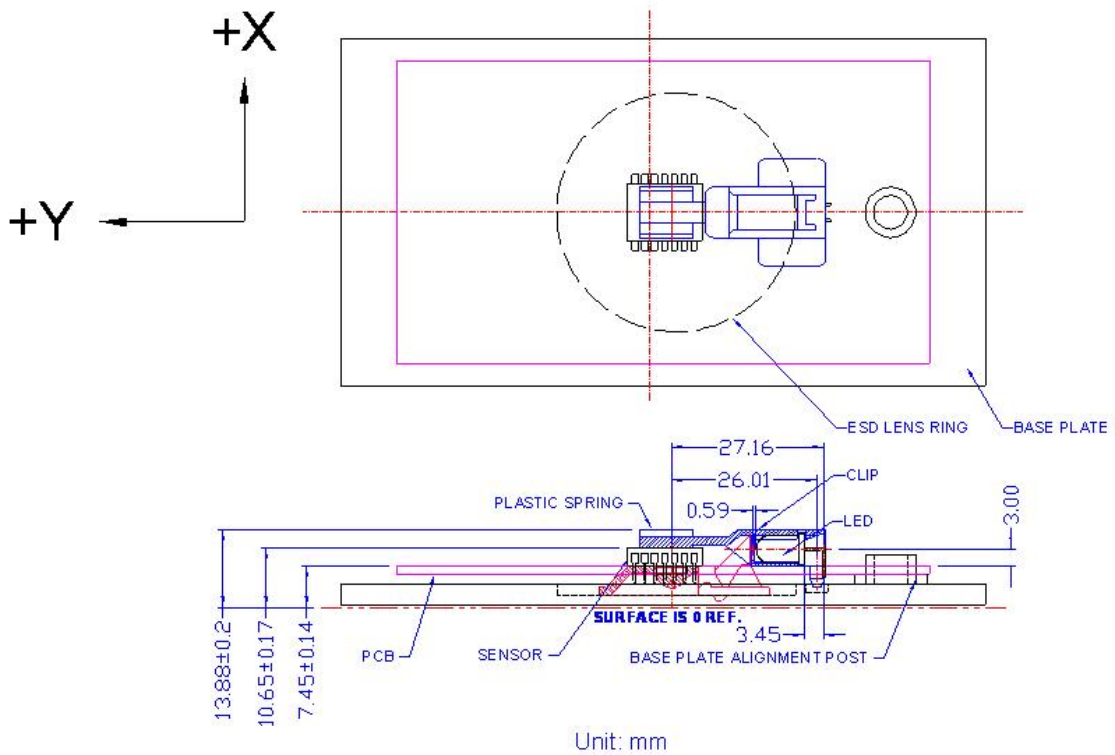

Figure 6. 2D Assembly

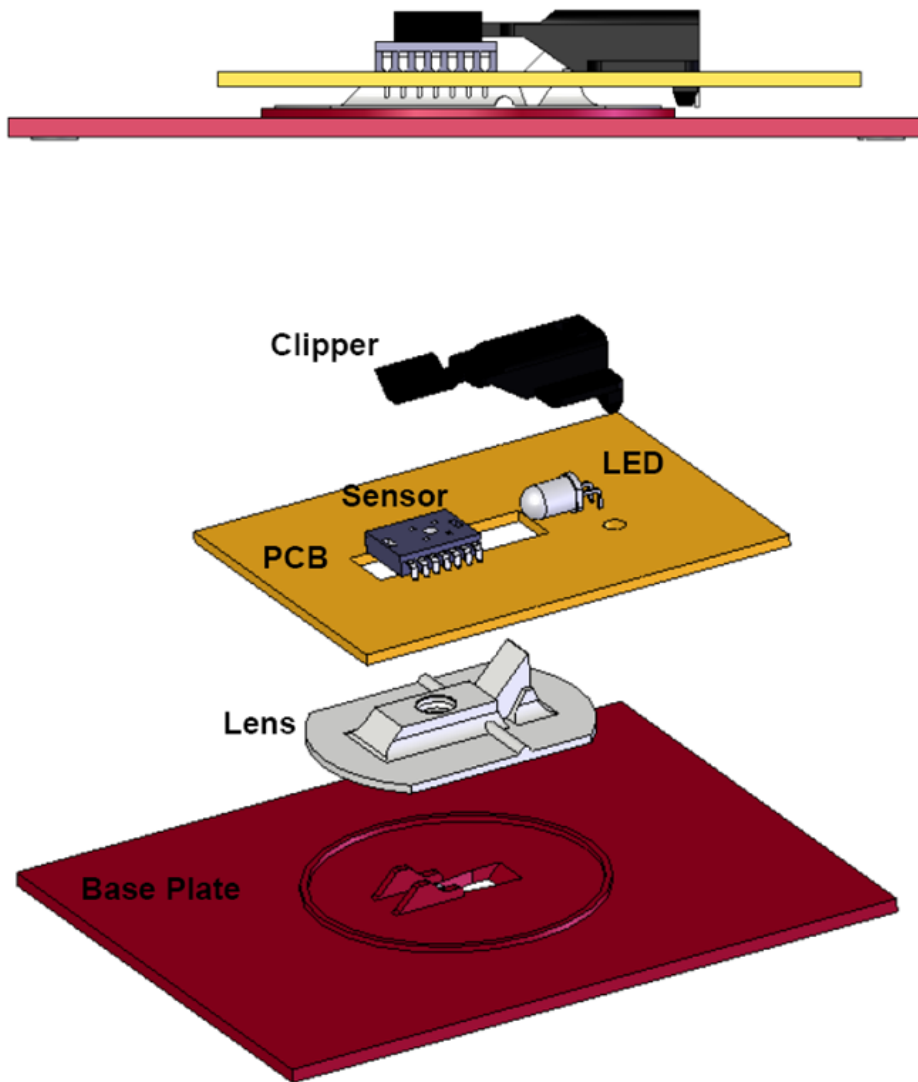

Figure 7. 3D Assembly for Mounting Instructions

5. USB Interface

5.1 USB Command Set Description (USB Descriptor)

The USB HOST detects USB mouse device plug-in and assigns a new unique address to the USB mouse device, then asking USB mouse device for information about the device description, configuration description, and assigning a configuration value for USB mouse device during enumeration period. After enumeration, the USB mouse device is able to transfer motion and button value to the USB host.

Descriptor Type	Byte	Byte	Byte	Byte	Byte	Byte	Byte	Byte
Device Descriptor (18 bytes)	12	01	10	01	00	00	00	08
	3A	09	10	25	00	01	01	02
	00	01						
Configuration Descriptor (9 bytes)	09	02	22	00	01	01	04	A0
	32							
Interface Descriptor (9 bytes)	09	04	00	00	01	03	01	02
	00							
Human Interface Device Descriptor (9 bytes)	09	21	10	01	00	01	22	3E
	00							
Endpoint Descriptor (7 bytes)	07	05	81	03	04	00	0A	
Human Interface Device Report Descriptor (62 bytes, 3D3B)	05	01	09	02	A1	01	05	09
	19	01	29	03	15	00	25	01
	95	03	75	01	81	02	95	01
	75	05	81	03	05	01	09	01
	A1	00	09	30	09	31	15	81
	25	7F	75	08	95	02	81	06
	C0	09	38	15	81	25	7F	75
	08	95	01	81	06	C0		
Language String Descriptor (4 bytes)	04	03	09	04				
Manufacture String Descriptor	PIXART							
Product String Descriptor	USB OPTICAL MOUSE							
Configuration String Descriptor	HID-compliant MOUSE							

5.2 USB Data Report Format

The USB report has two data formats, depending on boot or report protocol is selected. One kind of data format is the boot protocol used in legacy environment as 5.2.1. The other kind of data format is USB report protocol format which includes Z-wheel movement data in the fourth byte as 5.2.2. The Z-wheel is moved forward the fourth byte data is 01H, the Z-wheel is moved backward the fourth byte data is FFH, and the Z-wheel is idle the fourth byte data is 00H.

5.2.1 USB Boot Protocol for Legacy Operation

Byte	Bit	Symbol	Description
1	0	BL	1 = Left button pressed
	1	BR	1 = Right button pressed
	2	BM	1 = Middle button pressed
	3 ~ 7	NC	Reserved
2	0 - 7	X0 ~ X7	X data (D0 - D7). A positive value indicates motion to the right; a negative value indicates motion to the left. Bit 0 = LSB.
3	0 - 7	Y0 ~ Y7	Y data (D0 - D7). A positive value indicates device motion upward; a negative value indicates motion downward. Bit 0 = LSB.

5.2.2 USB Report Protocol

Byte	Bit	Symbol	Description
1	0	BL	1 = Left button pressed
	1	BR	1 = Right button pressed
	2	BM	1 = Middle button pressed
	3	B4	Reserved
	4	B5	Reserved
	5 ~ 7	NC	Reserved
2	0 - 7	X0 ~ X7	X data (D0 - D7). A positive value indicates motion to the right; a negative value indicates motion to the left. Bit 0 = LSB.
3	0 - 7	Y0 ~ Y7	Y data (D0 - D7). A positive value indicates device motion upward; a negative value indicates motion downward. Bit 0 = LSB.
4	0 - 7	Z0 ~ Z7	Z-wheel motion data (D0 - D7). A positive value indicates device motion downward; a negative value indicates motion upward. The Z0 - Z7 limit value is ± 7 . Bit 0 = LSB.

6. Referencing Application Circuit

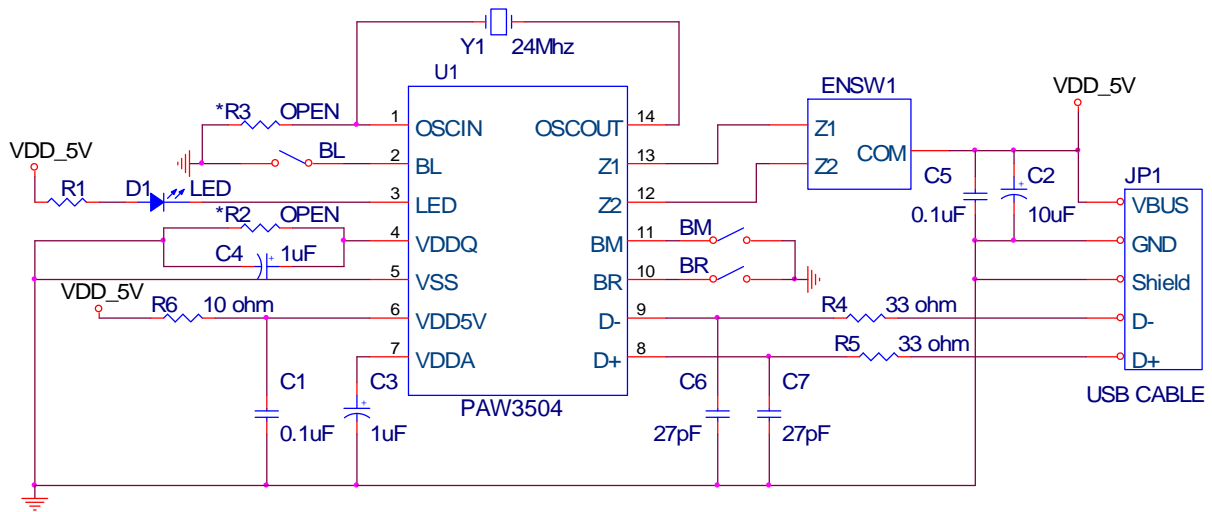

Note:

1. *R2 is left for PAW3401 with PS/2 interface
2. *R3 is left for PAW3504 RC Oscillator
3. R4,R5,C6,C7 are for EMC immunity
4. USB cable connector JP1 is suggested to have the pin sequence like this:
VBUS, GND, Shield, D-, D+

Figure 8. Application Circuit for PAW3504

6.2 PCB Layout Guideline

The following guidelines apply to component placement and routing on the PCB. That will get an optimum EMC solution and tracking performance.

6.2.1 Key Components Placement Rules

1. Place resonator (Y1) near SENSOR pin1 and pin 14.
2. Place bulk capacitor (C2) and bypass (C5) near the USB CABLE.
3. Place C1 and C3 near SENSOR pin 6 and pin 7.
4. The C6/C7 and R4/R5 should be placed as close to the USB CABLE.

6.2.2 Routing Rules

1. Caps for pins 4, 6, 7 trace length must be less than 5 mm.
2. The trace length of OSCOUT, OSCIN must be less than 10 mm.
3. Other general rules refer file "PAW3504DLY PCB Layout Guide"

6.3 Recommended Value for R1

Radiometric intensity of LED
Bin limits (mW/Sr at 20mA)

LED Bin Grade	Min	Typ	Max	Unit
N	14.7	-	17.7	mW/Sr
P	17.7	-	21.2	mW/Sr
Q	21.2	-	25.4	mW/Sr

Note: Tolerance for each bin will be $\pm 15\%$

R1 value (ohm), $V_{DD} = 5.0V$

LED Bin Grade	Min	Typ	Max	Unit
N	56.2	100	-	ohm
P	56.2	100	-	ohm
Q	56.2	100	-	ohm

6.4 Resonator Suggestion

The following figure shows chip internal resonator circuit, and the table shows its external parameters. PixArt strongly recommends the user using resonators which can work properly by 1.8V.

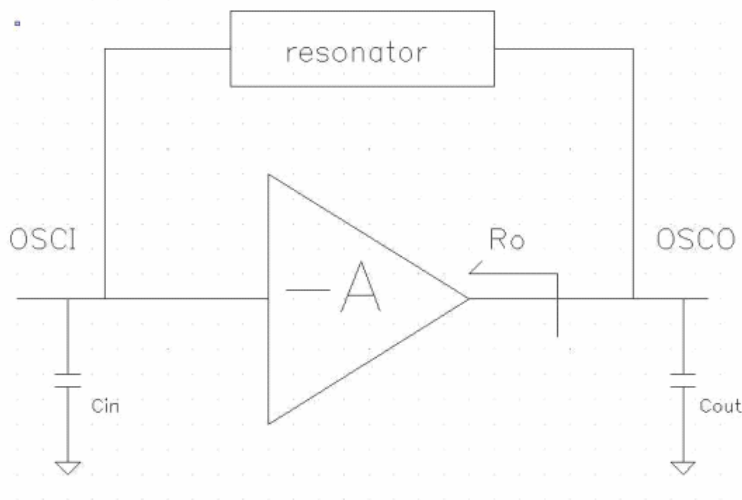

Figure 9. Application Circuit for PAW3504

External Parameters	
I/O Voltage	3.3V
Cin	12.5pF ~ 15pF
Cout	12.5pF ~ 15pF
Impedance	966K ~ 1.78M ohm
Accuracy	24MHz +/- 1.5%

7. Package Information

7.1 Package Outline Drawing

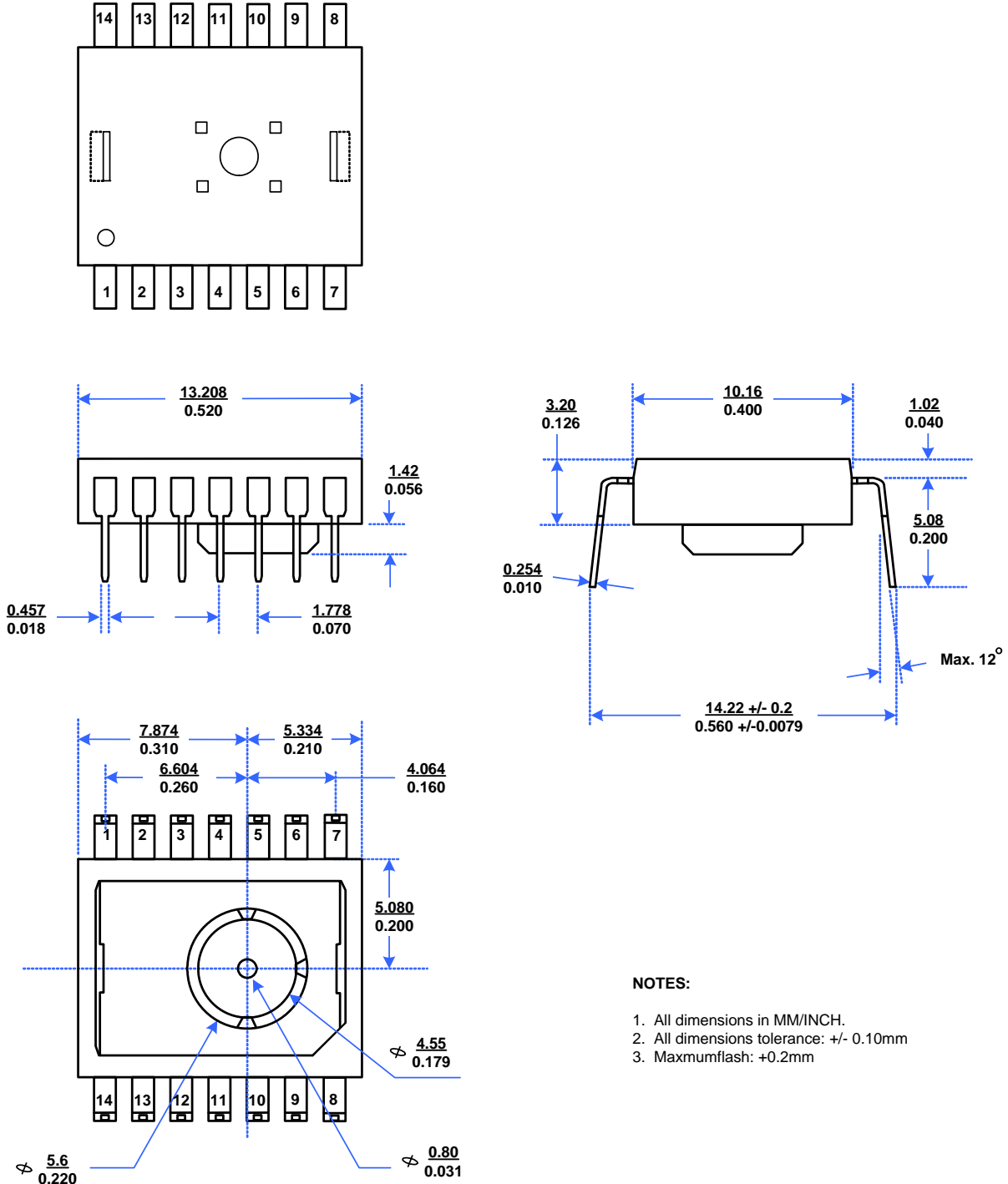

Figure 10. Package Outline Drawing

7.2 Recommended PCB Mechanical Cutouts and Spacing

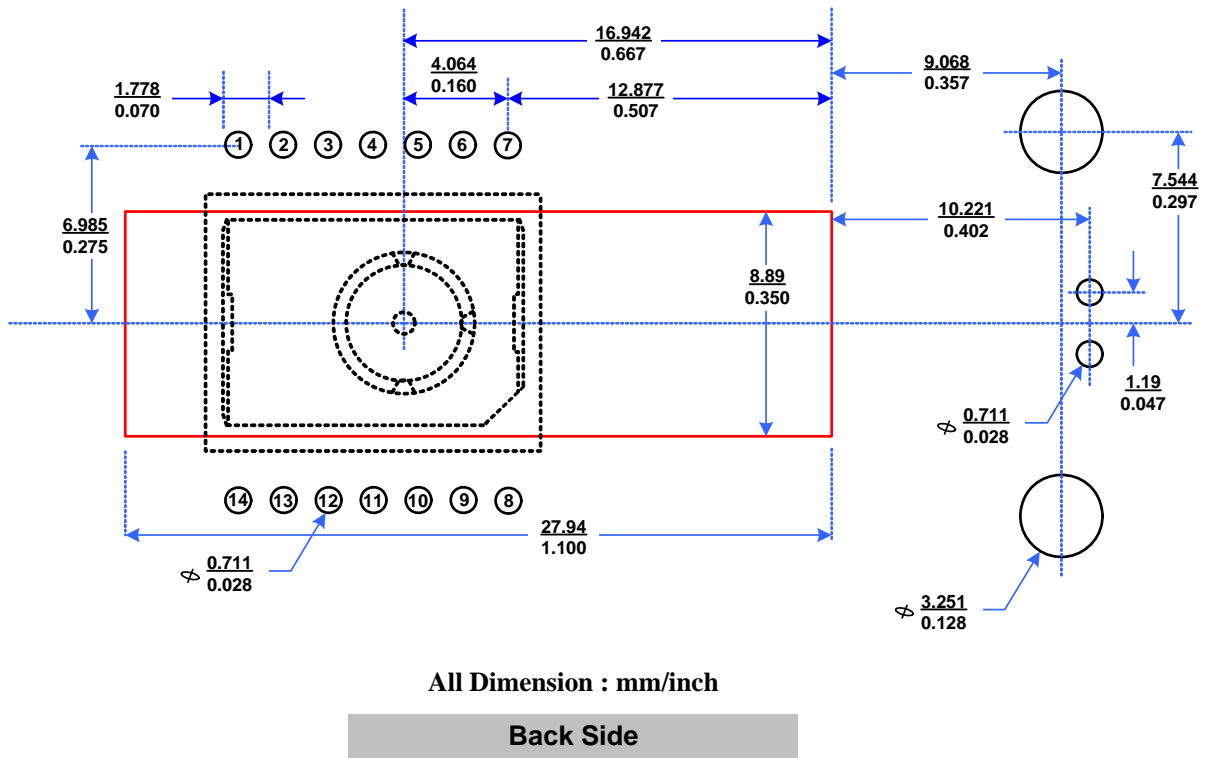

Figure 11. Recommended PCB Mechanical Cutouts and Spacing

8. Update History

Version	Update	Date
V1.0	Creation, Preliminary 1 st version	06/09/2008
V1.1	Content Revised, and Added Ch3.6, 6.4	02/06/2009
V1.2	Added patent announcement per page-end	01/22/2010

Note: The Part No. of the Mouse Product with Prefix "PAN" shall NOT be made, sold, offered to sell, imported or used in or into USA, Canada, Japan and EU. For "PAN", PixArt has only gained territory-limited patent license from Avago. Avago reserve right to take legal action against our customers who fails to comply the above term. PLEASE NOTE THAT PixArt will NOT defend, indemnify, or provide any assistance to our customers who fail to comply the term. IF YOU DO NOT AGREE THE TERM, PIXART WILL NOT DELIVER "PAN" PRODUCTS TO YOU.